

ENGINEERING  
TOMORROW

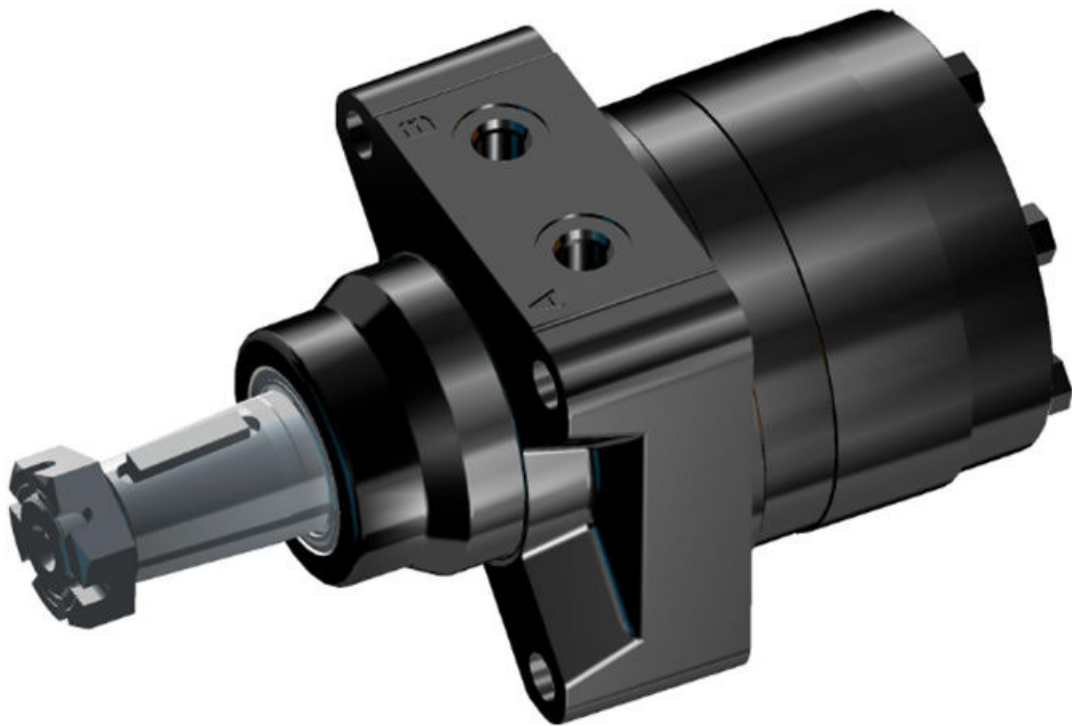

Technical Information

# Orbital Motor A-Delta



**Revision history**

*Table of revisions*

<b>Date</b>	<b>Changed</b>	<b>Rev</b>
August 2023	First edition	0101

## Contents

### A-Delta Series

Overview.....	4
Benefits.....	4
Typical Applications.....	4
A-Delta Series Technical Information.....	4
Performance Data.....	5
A-Delta Series Housing.....	8
Allowable Shaft Load / Bearing Curve.....	9
A-Delta Series Output Shaft.....	10
A-Delta Series Ordering Information.....	10
Recommended Code Numbers.....	12

## A-Delta Series

### A-Delta Series Overview

A-Delta series motor is a part of the Danfoss orbital motor production line, which provides torques up to 1179 Nm. Danfoss has packed this motor with many of the "best in class" features: The optimized geroler profile ensures smooth operation; the disc valve technology has the best performance and stronger gradeability.

#### A-Delta Series Benefits

- Lower no load pressure drop which leads to longer life and lower temperature operation
- Wheel drive motor, high performance bearing, withstand high radial force
- Disc valve design ensures well stability at low speed
- High total efficiency and longer service life

#### A-Delta Series Typical Applications

The A-Delta series motor is suitable for the wheel drive of small machines like an aerial work platform, mini excavators less than 1 ton, mini skid steer loaders and many more.

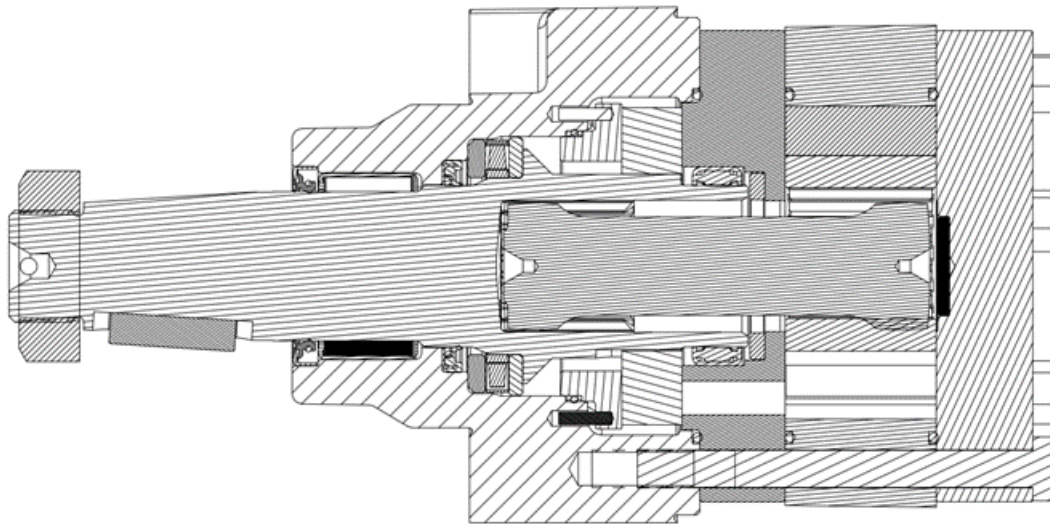

### A-Delta Series Technical Information

		MCDL146	MCDL198	MCDL252	MCDL300	MCDL347	MCDL375	MCDL395
Displacement/cc		146	198	252	300	347	362.9	395
Flow/LPM	Continuous	15	20	25	30	30	30	30
	Intermittent	23	30	38	45	45	45	45
Speed/RPM	Continuous	98	98	95	98	85	81	74
	Intermittent	150	150	150	147	127	121	112
Torque/Nm	Continuous	395	535	680	800	924	960	972
	Intermittent	515	735	880	1012	1138	1080	1179
Pressure/ $\Delta$ bar	Continuous	205	205	205	205	205	205	190
	Intermittent	275	275	275	275	275	241	241

To ensure the best motor life, run the motor in low speed high torque mode at approximately 30% of continuous pressure and 50% of continuous flow for 30 minutes in each direction before application of full load. Ensure that the motor is filled with fluid prior to operation.

## A-Delta Series

When pressurizing B port, all displacements have a continuous rating of 138 bar (2000 psi).

### Maximum inlet pressure:

310 bar (4500 psi). Do not exceed  $\Delta$  pressure rating shown in the table above.

### Recommended fluids:

Premium quality, anti-wear type hydraulic oil with viscosity of no less than 13 cSt [70 SUS] at operating temperature.

### Recommended system operating temp:

-34°C to 82°C

[-30°F to 180°F]

### Recommended filtration:

Per ISO Cleanliness code, 4406: 20/18/13.

### Warning

Thermal shock warning:

Do not operate the motor with fluid that is 21°C (70°F) or more above the motor temperature.

### Warning

Minimum Delta pressure warning:

Motors must not run with equal inlet and outlet pressure 3.5 bar (50 PSID). Minimum Delta pressure between motor ports is always required (expect when switching direction of rotation).

## A-Delta Series Performance Data

Motors run with high efficiency in all areas designated with a number for torque and speed. For best motor life, select a motor to run with a torque and speed range according to the table of continuous or intermittent values.

Performance data is typical at 25 cSt [120 SUS]. Actual data may vary slightly from unit to unit in production.

146cm<sup>3</sup>/r

	$\Delta$ Bar	17	34	52	69	86	103	121	138	155	172	190	205	224	241	259	275
LPM																	
7.6	Nm	32 <sup>1</sup>	67 <sup>1</sup>	102 <sup>1</sup>	134 <sup>1</sup>	163 <sup>1</sup>	194 <sup>1</sup>	225 <sup>1</sup>	254 <sup>1</sup>	286 <sup>1</sup>	317 <sup>1</sup>	343 <sup>1</sup>	385 <sup>1</sup>	434 <sup>2</sup>	434 <sup>2</sup>	451 <sup>2</sup>	
	RPM	50 <sup>1</sup>	48 <sup>1</sup>	46 <sup>1</sup>	42 <sup>1</sup>	44 <sup>1</sup>	43 <sup>1</sup>	40 <sup>1</sup>	39 <sup>1</sup>	38 <sup>1</sup>	37 <sup>1</sup>	35 <sup>1</sup>	33 <sup>1</sup>	29 <sup>2</sup>	27 <sup>2</sup>	24 <sup>2</sup>	
15	Nm	32 <sup>1</sup>	69 <sup>1</sup>	107 <sup>1</sup>	143 <sup>1</sup>	176 <sup>1</sup>	213 <sup>1</sup>	251 <sup>1</sup>	280 <sup>1</sup>	311 <sup>1</sup>	343 <sup>1</sup>	372 <sup>1</sup>	395 <sup>1</sup>	442 <sup>2</sup>	467 <sup>2</sup>	475 <sup>2</sup>	505 <sup>2</sup>
	RPM	98 <sup>1</sup>	98 <sup>1</sup>	97 <sup>1</sup>	96 <sup>1</sup>	95 <sup>1</sup>	95 <sup>1</sup>	94 <sup>1</sup>	92 <sup>1</sup>	89 <sup>1</sup>	87 <sup>1</sup>	82 <sup>1</sup>	79 <sup>1</sup>	75 <sup>2</sup>	72 <sup>2</sup>	67 <sup>2</sup>	62 <sup>2</sup>
23	Nm	31 <sup>2</sup>	68 <sup>2</sup>	105 <sup>2</sup>	142 <sup>2</sup>	175 <sup>2</sup>	213 <sup>2</sup>	248 <sup>2</sup>	385 <sup>2</sup>	320 <sup>2</sup>	357 <sup>2</sup>	384 <sup>2</sup>	417 <sup>2</sup>	451 <sup>2</sup>	481 <sup>2</sup>	502 <sup>2</sup>	515 <sup>2</sup>
	RPM	150 <sup>2</sup>	150 <sup>2</sup>	149 <sup>2</sup>	148 <sup>2</sup>	146 <sup>2</sup>	145 <sup>2</sup>	144 <sup>2</sup>	143 <sup>2</sup>	141 <sup>2</sup>	137 <sup>2</sup>	135 <sup>2</sup>	132 <sup>2</sup>	129 <sup>2</sup>	124 <sup>2</sup>	119 <sup>2</sup>	113 <sup>2</sup>

<sup>1</sup> Continuous

<sup>2</sup> Intermittent

A-Delta Series

198cm<sup>3</sup>/r

	$\Delta$ Bar	17	34	52	69	86	103	121	138	155	172	190	205	224	241	259	275
LPM																	
7.6	Nm	35 <sup>1</sup>	83 <sup>1</sup>	126 <sup>1</sup>	167 <sup>1</sup>	211 <sup>1</sup>	254 <sup>1</sup>	301 <sup>1</sup>	345 <sup>1</sup>	389 <sup>1</sup>	432 <sup>1</sup>	473 <sup>1</sup>	513 <sup>1</sup>	550 <sup>2</sup>	586 <sup>2</sup>	622 <sup>2</sup>	
	RPM	36 <sup>1</sup>	35 <sup>1</sup>	34 <sup>1</sup>	32 <sup>1</sup>	31 <sup>1</sup>	30 <sup>1</sup>	29 <sup>1</sup>	27 <sup>1</sup>	27 <sup>1</sup>	24 <sup>1</sup>	24 <sup>1</sup>	22 <sup>1</sup>	21 <sup>2</sup>	18 <sup>2</sup>	17 <sup>2</sup>	
15	Nm	41 <sup>1</sup>	91 <sup>1</sup>	139 <sup>1</sup>	185 <sup>1</sup>	230 <sup>1</sup>	275 <sup>1</sup>	321 <sup>1</sup>	365 <sup>1</sup>	409 <sup>1</sup>	453 <sup>1</sup>	497 <sup>1</sup>	535 <sup>1</sup>	583 <sup>2</sup>	626 <sup>2</sup>	668 <sup>2</sup>	708 <sup>2</sup>
	RPM	41 <sup>1</sup>	91 <sup>1</sup>	139 <sup>1</sup>	185 <sup>1</sup>	230 <sup>1</sup>	275 <sup>1</sup>	321 <sup>1</sup>	365 <sup>1</sup>	409 <sup>1</sup>	453 <sup>1</sup>	497 <sup>1</sup>	535 <sup>1</sup>	583 <sup>2</sup>	626 <sup>2</sup>	668 <sup>2</sup>	708 <sup>2</sup>
20	Nm	41 <sup>1</sup>	90 <sup>1</sup>	138 <sup>1</sup>	185 <sup>1</sup>	232 <sup>1</sup>	277 <sup>1</sup>	322 <sup>1</sup>	366 <sup>1</sup>	410 <sup>1</sup>	455 <sup>1</sup>	498 <sup>1</sup>	532 <sup>1</sup>	588 <sup>2</sup>	630 <sup>2</sup>	671 <sup>2</sup>	735 <sup>2</sup>
	RPM	98 <sup>1</sup>	98 <sup>1</sup>	97 <sup>1</sup>	95 <sup>1</sup>	94 <sup>1</sup>	92 <sup>1</sup>	90 <sup>1</sup>	88 <sup>1</sup>	86 <sup>1</sup>	85 <sup>1</sup>	82 <sup>1</sup>	80 <sup>1</sup>	79 <sup>2</sup>	78 <sup>2</sup>	78 <sup>2</sup>	77 <sup>2</sup>
23	Nm	41 <sup>2</sup>	90 <sup>2</sup>	139 <sup>2</sup>	187 <sup>2</sup>	233 <sup>2</sup>	279 <sup>2</sup>	325 <sup>2</sup>	369 <sup>2</sup>	414 <sup>2</sup>	458 <sup>2</sup>	502 <sup>2</sup>	546 <sup>2</sup>	589 <sup>2</sup>	632 <sup>2</sup>	675 <sup>2</sup>	725 <sup>2</sup>
	RPM	112 <sup>2</sup>	111 <sup>2</sup>	110 <sup>2</sup>	109 <sup>2</sup>	107 <sup>2</sup>	106 <sup>2</sup>	104 <sup>2</sup>	102 <sup>2</sup>	101 <sup>2</sup>	99 <sup>2</sup>	98 <sup>2</sup>	96 <sup>2</sup>	95 <sup>2</sup>	93 <sup>2</sup>	92 <sup>2</sup>	89 <sup>2</sup>
30	Nm	34 <sup>2</sup>	88 <sup>2</sup>	138 <sup>2</sup>	186 <sup>2</sup>	234 <sup>2</sup>	280 <sup>2</sup>	327 <sup>2</sup>	373 <sup>2</sup>	418 <sup>2</sup>	462 <sup>2</sup>	506 <sup>2</sup>	549 <sup>2</sup>	591 <sup>2</sup>	633 <sup>2</sup>	675 <sup>2</sup>	717 <sup>2</sup>
	RPM	150 <sup>2</sup>	150 <sup>2</sup>	149 <sup>2</sup>	147 <sup>2</sup>	146 <sup>2</sup>	145 <sup>2</sup>	143 <sup>2</sup>	142 <sup>2</sup>	140 <sup>2</sup>	138 <sup>2</sup>	135 <sup>2</sup>	134 <sup>2</sup>	133 <sup>2</sup>	131 <sup>2</sup>	129 <sup>2</sup>	124 <sup>2</sup>

252cm<sup>3</sup>/r

	$\Delta$ Bar	17	34	52	69	86	103	121	138	155	172	190	205	224	241	259	275
LPM																	
7.6	Nm	55 <sup>1</sup>	114 <sup>1</sup>	172 <sup>1</sup>	229 <sup>1</sup>	289 <sup>1</sup>	345 <sup>1</sup>	403 <sup>1</sup>	459 <sup>1</sup>	515 <sup>1</sup>	574 <sup>1</sup>	613 <sup>1</sup>	658 <sup>1</sup>	724 <sup>2</sup>	778 <sup>2</sup>	834 <sup>2</sup>	
	RPM	28 <sup>1</sup>	27 <sup>1</sup>	26 <sup>1</sup>	26 <sup>1</sup>	25 <sup>1</sup>	24 <sup>1</sup>	23 <sup>1</sup>	23 <sup>1</sup>	22 <sup>1</sup>	23 <sup>1</sup>	23 <sup>1</sup>	22 <sup>1</sup>	22 <sup>2</sup>	19 <sup>2</sup>	19 <sup>2</sup>	
15	Nm	57 <sup>1</sup>	119 <sup>1</sup>	179 <sup>1</sup>	242 <sup>1</sup>	301 <sup>1</sup>	355 <sup>1</sup>	421 <sup>1</sup>	477 <sup>1</sup>	534 <sup>1</sup>	584 <sup>1</sup>	636 <sup>1</sup>	670 <sup>1</sup>	740 <sup>2</sup>	790 <sup>2</sup>	840 <sup>2</sup>	880 <sup>2</sup>
	RPM	59 <sup>1</sup>	57 <sup>1</sup>	56 <sup>1</sup>	56 <sup>1</sup>	55 <sup>1</sup>	55 <sup>1</sup>	54 <sup>1</sup>	54 <sup>1</sup>	53 <sup>1</sup>	53 <sup>1</sup>	53 <sup>1</sup>	51 <sup>1</sup>	51 <sup>2</sup>	49 <sup>2</sup>	49 <sup>2</sup>	47 <sup>2</sup>
23	Nm	51 <sup>1</sup>	116 <sup>1</sup>	179 <sup>1</sup>	241 <sup>1</sup>	301 <sup>1</sup>	361 <sup>1</sup>	420 <sup>1</sup>	477 <sup>1</sup>	534 <sup>1</sup>	590 <sup>1</sup>	646 <sup>1</sup>	677 <sup>1</sup>	756 <sup>2</sup>	810 <sup>2</sup>	865 <sup>2</sup>	875 <sup>2</sup>
	RPM	89 <sup>1</sup>	88 <sup>1</sup>	86 <sup>1</sup>	85 <sup>1</sup>	85 <sup>1</sup>	84 <sup>1</sup>	84 <sup>1</sup>	84 <sup>1</sup>	84 <sup>1</sup>	84 <sup>1</sup>	83 <sup>1</sup>	82 <sup>1</sup>	82 <sup>2</sup>	80 <sup>2</sup>	78 <sup>2</sup>	78 <sup>2</sup>
25	Nm	60 <sup>1</sup>	116 <sup>1</sup>	177 <sup>1</sup>	240 <sup>1</sup>	300 <sup>1</sup>	358 <sup>1</sup>	419 <sup>1</sup>	479 <sup>1</sup>	538 <sup>1</sup>	588 <sup>1</sup>	650 <sup>1</sup>	680 <sup>1</sup>	755 <sup>2</sup>	811 <sup>2</sup>	868 <sup>2</sup>	880 <sup>2</sup>
	RPM	95 <sup>1</sup>	93 <sup>1</sup>	92 <sup>1</sup>	90 <sup>1</sup>	91 <sup>1</sup>	90 <sup>1</sup>	90 <sup>1</sup>	91 <sup>1</sup>	88 <sup>1</sup>	87 <sup>1</sup>	87 <sup>1</sup>	86 <sup>1</sup>	85 <sup>2</sup>	86 <sup>2</sup>	84 <sup>2</sup>	83 <sup>2</sup>
30	Nm	47 <sup>2</sup>	114 <sup>2</sup>	177 <sup>2</sup>	239 <sup>2</sup>	301 <sup>2</sup>	360 <sup>2</sup>	420 <sup>2</sup>	477 <sup>2</sup>	534 <sup>2</sup>	590 <sup>2</sup>	646 <sup>2</sup>	701 <sup>2</sup>	754 <sup>2</sup>	808 <sup>2</sup>	861 <sup>2</sup>	870 <sup>2</sup>
	RPM	118 <sup>2</sup>	118 <sup>2</sup>	117 <sup>2</sup>	115 <sup>2</sup>	114 <sup>2</sup>	113 <sup>2</sup>	114 <sup>2</sup>	113 <sup>2</sup>	111 <sup>2</sup>	110 <sup>2</sup>	109 <sup>2</sup>	110 <sup>2</sup>	111 <sup>2</sup>	110 <sup>2</sup>	109 <sup>2</sup>	108 <sup>2</sup>
38	Nm	37 <sup>2</sup>	108 <sup>2</sup>	171 <sup>2</sup>	233 <sup>2</sup>	295 <sup>2</sup>	354 <sup>2</sup>	414 <sup>2</sup>	472 <sup>2</sup>	528 <sup>2</sup>	582 <sup>2</sup>	636 <sup>2</sup>	690 <sup>2</sup>	744 <sup>2</sup>	797 <sup>2</sup>	849 <sup>2</sup>	874 <sup>2</sup>
	RPM	150 <sup>2</sup>	148 <sup>2</sup>	147 <sup>2</sup>	145 <sup>2</sup>	144 <sup>2</sup>	143 <sup>2</sup>	142 <sup>2</sup>	142 <sup>2</sup>	142 <sup>2</sup>	143 <sup>2</sup>	142 <sup>2</sup>	142 <sup>2</sup>	141 <sup>2</sup>	140 <sup>2</sup>	139 <sup>2</sup>	138 <sup>2</sup>

300cm<sup>3</sup>/r

	$\Delta$ Bar	17	34	52	69	86	103	121	138	155	172	190	205	224	241	259	275
LPM																	
7.6	Nm	69 <sup>1</sup>	142 <sup>1</sup>	217 <sup>1</sup>	288 <sup>1</sup>	361 <sup>1</sup>	432 <sup>1</sup>	505 <sup>1</sup>	574 <sup>1</sup>	644 <sup>1</sup>	712 <sup>1</sup>	779 <sup>1</sup>	796 <sup>1</sup>	905 <sup>2</sup>	958 <sup>2</sup>	1002 <sup>2</sup>	
	RPM	24 <sup>1</sup>	23 <sup>1</sup>	23 <sup>1</sup>	22 <sup>1</sup>	21 <sup>1</sup>	21 <sup>1</sup>	21 <sup>1</sup>	20 <sup>1</sup>	19 <sup>1</sup>	18 <sup>1</sup>	17 <sup>1</sup>	16 <sup>1</sup>	15 <sup>2</sup>	13 <sup>2</sup>	11 <sup>2</sup>	
15	Nm	69 <sup>1</sup>	145 <sup>1</sup>	219 <sup>1</sup>	292 <sup>1</sup>	364 <sup>1</sup>	435 <sup>1</sup>	506 <sup>1</sup>	575 <sup>1</sup>	643 <sup>1</sup>	710 <sup>1</sup>	777 <sup>1</sup>	797 <sup>1</sup>	906 <sup>2</sup>	968 <sup>2</sup>	1009 <sup>2</sup>	1012 <sup>2</sup>
	RPM	49 <sup>1</sup>	48 <sup>1</sup>	47 <sup>1</sup>	46 <sup>1</sup>	45 <sup>1</sup>	44 <sup>1</sup>	44 <sup>1</sup>	44 <sup>1</sup>	43 <sup>1</sup>	42 <sup>1</sup>	41 <sup>1</sup>	40 <sup>1</sup>	40 <sup>2</sup>	39 <sup>2</sup>	38 <sup>2</sup>	37 <sup>2</sup>
23	Nm	64 <sup>1</sup>	141 <sup>1</sup>	215 <sup>1</sup>	288 <sup>1</sup>	359 <sup>1</sup>	429 <sup>1</sup>	499 <sup>1</sup>	567 <sup>1</sup>	634 <sup>1</sup>	700 <sup>1</sup>	765 <sup>1</sup>	800 <sup>1</sup>	892 <sup>2</sup>	954 <sup>2</sup>	1005 <sup>2</sup>	1011 <sup>2</sup>
	RPM	76 <sup>1</sup>	74 <sup>1</sup>	73 <sup>1</sup>	71 <sup>1</sup>	70 <sup>1</sup>	69 <sup>1</sup>	68 <sup>1</sup>	68 <sup>1</sup>	69 <sup>1</sup>	68 <sup>1</sup>	68 <sup>1</sup>	67 <sup>1</sup>	66 <sup>2</sup>	65 <sup>2</sup>	64 <sup>2</sup>	63 <sup>2</sup>
30	Nm	53 <sup>1</sup>	129 <sup>1</sup>	211 <sup>1</sup>	285 <sup>1</sup>	356 <sup>1</sup>	427 <sup>1</sup>	497 <sup>1</sup>	565 <sup>1</sup>	633 <sup>1</sup>	698 <sup>1</sup>	762 <sup>1</sup>	790 <sup>1</sup>	890 <sup>2</sup>	952 <sup>2</sup>	1003 <sup>2</sup>	1010 <sup>2</sup>
	RPM	98 <sup>1</sup>	98 <sup>1</sup>	97 <sup>1</sup>	96 <sup>1</sup>	94 <sup>1</sup>	93 <sup>1</sup>	92 <sup>1</sup>	92 <sup>1</sup>	92 <sup>1</sup>	93 <sup>1</sup>	93 <sup>1</sup>	93 <sup>1</sup>	91 <sup>2</sup>	90 <sup>2</sup>	86 <sup>2</sup>	85 <sup>2</sup>

A-Delta Series

300cm<sup>3</sup>/r (continued)

	$\Delta$ Bar	17	34	52	69	86	103	121	138	155	172	190	205	224	241	259	275
38	Nm	50 <sup>2</sup>	119 <sup>2</sup>	196 <sup>2</sup>	267 <sup>2</sup>	339 <sup>2</sup>	413 <sup>2</sup>	482 <sup>2</sup>	561 <sup>2</sup>	629 <sup>2</sup>	695 <sup>2</sup>	759 <sup>2</sup>	821 <sup>2</sup>	882 <sup>2</sup>	943 <sup>2</sup>	1003 <sup>2</sup>	1008 <sup>2</sup>
	RPM	126 <sup>2</sup>	126 <sup>2</sup>	124 <sup>2</sup>	122 <sup>2</sup>	120 <sup>2</sup>	118 <sup>2</sup>	115 <sup>2</sup>	113 <sup>2</sup>	113 <sup>2</sup>	113 <sup>2</sup>	114 <sup>2</sup>	116 <sup>2</sup>	118 <sup>2</sup>	118 <sup>2</sup>	117 <sup>2</sup>	117 <sup>2</sup>
45	Nm	46 <sup>2</sup>	114 <sup>2</sup>	192 <sup>2</sup>	264 <sup>2</sup>	340 <sup>2</sup>	409 <sup>2</sup>	486 <sup>2</sup>	555 <sup>2</sup>	624 <sup>2</sup>	690 <sup>2</sup>	754 <sup>2</sup>	817 <sup>2</sup>	879 <sup>2</sup>	941 <sup>2</sup>	1002 <sup>2</sup>	1008 <sup>2</sup>
	RPM	147 <sup>2</sup>	147 <sup>2</sup>	146 <sup>2</sup>	146 <sup>2</sup>	145 <sup>2</sup>	143 <sup>2</sup>	141 <sup>2</sup>	140 <sup>2</sup>	139 <sup>2</sup>	139 <sup>2</sup>	140 <sup>2</sup>	142 <sup>2</sup>	144 <sup>2</sup>	144 <sup>2</sup>	144 <sup>2</sup>	144 <sup>2</sup>

347cm<sup>3</sup>/r

	$\Delta$ Bar	17	34	52	69	86	103	121	138	155	172	190	205	224	241	259	275
LPM																	
7.6	Nm	78 <sup>1</sup>	160 <sup>1</sup>	240 <sup>1</sup>	319 <sup>1</sup>	399 <sup>1</sup>	480 <sup>1</sup>	558 <sup>1</sup>	636 <sup>1</sup>	711 <sup>1</sup>	786 <sup>1</sup>	855 <sup>1</sup>	924 <sup>1</sup>	987 <sup>2</sup>	1040 <sup>2</sup>	1087 <sup>2</sup>	
	RPM	20 <sup>1</sup>	19 <sup>1</sup>	18 <sup>1</sup>	18 <sup>1</sup>	17 <sup>1</sup>	18 <sup>1</sup>	17 <sup>1</sup>	17 <sup>1</sup>	16 <sup>1</sup>	15 <sup>1</sup>	14 <sup>1</sup>	13 <sup>1</sup>	12 <sup>2</sup>	9 <sup>2</sup>	8 <sup>2</sup>	
15	Nm	78 <sup>1</sup>	163 <sup>1</sup>	246 <sup>1</sup>	326 <sup>1</sup>	407 <sup>1</sup>	486 <sup>1</sup>	563 <sup>1</sup>	638 <sup>1</sup>	713 <sup>1</sup>	786 <sup>1</sup>	860 <sup>1</sup>	923 <sup>1</sup>	1004 <sup>2</sup>	1074 <sup>2</sup>	1143 <sup>2</sup>	1138 <sup>2</sup>
	RPM	42 <sup>1</sup>	41 <sup>1</sup>	41 <sup>1</sup>	40 <sup>1</sup>	39 <sup>1</sup>	37 <sup>1</sup>	38 <sup>1</sup>	38 <sup>1</sup>	39 <sup>1</sup>	38 <sup>1</sup>	38 <sup>1</sup>	37 <sup>1</sup>	37 <sup>2</sup>	35 <sup>2</sup>	33 <sup>2</sup>	31 <sup>2</sup>
23	Nm	73 <sup>1</sup>	159 <sup>1</sup>	243 <sup>1</sup>	324 <sup>1</sup>	404 <sup>1</sup>	483 <sup>1</sup>	561 <sup>1</sup>	637 <sup>1</sup>	710 <sup>1</sup>	781 <sup>1</sup>	854 <sup>1</sup>	923 <sup>1</sup>	995 <sup>2</sup>	1064 <sup>2</sup>	1132 <sup>2</sup>	1135 <sup>2</sup>
	RPM	64 <sup>1</sup>	64 <sup>1</sup>	63 <sup>1</sup>	61 <sup>1</sup>	60 <sup>1</sup>	58 <sup>1</sup>	57 <sup>1</sup>	57 <sup>1</sup>	59 <sup>1</sup>	60 <sup>1</sup>	60 <sup>1</sup>	59 <sup>1</sup>	58 <sup>2</sup>	57 <sup>2</sup>	56 <sup>2</sup>	55 <sup>2</sup>
30	Nm	68 <sup>1</sup>	153 <sup>1</sup>	238 <sup>1</sup>	319 <sup>1</sup>	400 <sup>1</sup>	479 <sup>1</sup>	558 <sup>1</sup>	635 <sup>1</sup>	708 <sup>1</sup>	779 <sup>1</sup>	849 <sup>1</sup>	919 <sup>1</sup>	990 <sup>2</sup>	1060 <sup>2</sup>	1129 <sup>2</sup>	1132 <sup>2</sup>
	RPM	85 <sup>1</sup>	85 <sup>1</sup>	85 <sup>1</sup>	84 <sup>1</sup>	82 <sup>1</sup>	81 <sup>1</sup>	79 <sup>1</sup>	78 <sup>1</sup>	79 <sup>1</sup>	81 <sup>1</sup>	82 <sup>1</sup>	81 <sup>1</sup>	81 <sup>2</sup>	80 <sup>2</sup>	78 <sup>2</sup>	77 <sup>2</sup>
38	Nm	62 <sup>2</sup>	146 <sup>2</sup>	230 <sup>2</sup>	312 <sup>2</sup>	394 <sup>2</sup>	473 <sup>2</sup>	552 <sup>2</sup>	631 <sup>2</sup>	707 <sup>2</sup>	779 <sup>2</sup>	847 <sup>2</sup>	913 <sup>2</sup>	979 <sup>2</sup>	1048 <sup>2</sup>	1116 <sup>2</sup>	1130 <sup>2</sup>
	RPM	108 <sup>2</sup>	108 <sup>2</sup>	107 <sup>2</sup>	106 <sup>2</sup>	104 <sup>2</sup>	103 <sup>2</sup>	100 <sup>2</sup>	98 <sup>2</sup>	97 <sup>2</sup>	98 <sup>2</sup>	100 <sup>2</sup>	103 <sup>2</sup>	103 <sup>2</sup>	102 <sup>2</sup>	102 <sup>2</sup>	101 <sup>2</sup>
45	Nm	54 <sup>2</sup>	139 <sup>2</sup>	223 <sup>2</sup>	305 <sup>2</sup>	385 <sup>2</sup>	464 <sup>2</sup>	542 <sup>2</sup>	619 <sup>2</sup>	694 <sup>2</sup>	766 <sup>2</sup>	835 <sup>2</sup>	902 <sup>2</sup>	969 <sup>2</sup>	1036 <sup>2</sup>	1103 <sup>2</sup>	1131 <sup>2</sup>
	RPM	127 <sup>2</sup>	127 <sup>2</sup>	126 <sup>2</sup>	126 <sup>2</sup>	127 <sup>2</sup>	125 <sup>2</sup>	122 <sup>2</sup>	119 <sup>2</sup>	117 <sup>2</sup>	115 <sup>2</sup>	115 <sup>2</sup>	119 <sup>2</sup>	123 <sup>2</sup>	125 <sup>2</sup>	125 <sup>2</sup>	124 <sup>2</sup>

362.9cm<sup>3</sup>/r

	$\Delta$ Bar	17	34	52	69	86	103	121	138	155	172	190	205	224	241
LPM															
7.6	Nm	81 <sup>1</sup>	168 <sup>1</sup>	251 <sup>1</sup>	335 <sup>1</sup>	418 <sup>1</sup>	501 <sup>1</sup>	584 <sup>1</sup>	667 <sup>1</sup>	745 <sup>1</sup>	820 <sup>1</sup>	894 <sup>1</sup>	960 <sup>1</sup>	1005 <sup>2</sup>	1050 <sup>2</sup>
	RPM	19 <sup>1</sup>	18 <sup>1</sup>	18 <sup>1</sup>	17 <sup>1</sup>	17 <sup>1</sup>	17 <sup>1</sup>	16 <sup>1</sup>	16 <sup>1</sup>	15 <sup>1</sup>	15 <sup>1</sup>	14 <sup>1</sup>	13 <sup>1</sup>	12 <sup>2</sup>	11 <sup>2</sup>
15	Nm	81 <sup>1</sup>	170 <sup>1</sup>	250 <sup>1</sup>	336 <sup>1</sup>	420 <sup>1</sup>	505 <sup>1</sup>	590 <sup>1</sup>	668 <sup>1</sup>	747 <sup>1</sup>	821 <sup>1</sup>	900 <sup>1</sup>	950 <sup>1</sup>	1010 <sup>2</sup>	1060 <sup>2</sup>
	RPM	41 <sup>1</sup>	41 <sup>1</sup>	40 <sup>1</sup>	40 <sup>1</sup>	39 <sup>1</sup>	38 <sup>1</sup>	38 <sup>1</sup>	39 <sup>1</sup>	38 <sup>1</sup>	37 <sup>1</sup>	37 <sup>1</sup>	36 <sup>1</sup>	36 <sup>2</sup>	35 <sup>2</sup>
23	Nm	77 <sup>1</sup>	169 <sup>1</sup>	252 <sup>1</sup>	333 <sup>1</sup>	421 <sup>1</sup>	504 <sup>1</sup>	585 <sup>1</sup>	670 <sup>1</sup>	750 <sup>1</sup>	825 <sup>1</sup>	895 <sup>1</sup>	945 <sup>1</sup>	1008 <sup>2</sup>	1065 <sup>2</sup>
	RPM	63 <sup>1</sup>	62 <sup>1</sup>	60 <sup>1</sup>	60 <sup>1</sup>	58 <sup>1</sup>	57 <sup>1</sup>	56 <sup>1</sup>	56 <sup>1</sup>	56 <sup>1</sup>	57 <sup>1</sup>	57 <sup>1</sup>	56 <sup>1</sup>	54 <sup>2</sup>	53 <sup>2</sup>
30	Nm	66 <sup>1</sup>	156 <sup>1</sup>	249 <sup>1</sup>	330 <sup>1</sup>	418 <sup>1</sup>	499 <sup>1</sup>	582 <sup>1</sup>	668 <sup>1</sup>	746 <sup>1</sup>	822 <sup>1</sup>	896 <sup>1</sup>	946 <sup>1</sup>	1006 <sup>2</sup>	1080 <sup>2</sup>
	RPM	81 <sup>1</sup>	81 <sup>1</sup>	80 <sup>1</sup>	81 <sup>1</sup>	80 <sup>1</sup>	79 <sup>1</sup>	78 <sup>1</sup>	78 <sup>1</sup>	79 <sup>1</sup>	78 <sup>1</sup>	77 <sup>1</sup>	76 <sup>1</sup>	75 <sup>2</sup>	75 <sup>2</sup>

A-Delta Series

362.9cm<sup>3</sup>/r (continued)

	$\Delta$ Bar	17	34	52	69	86	103	121	138	155	172	190	205	224	241
38	Nm	57 <sup>2</sup>	147 <sup>2</sup>	241 <sup>2</sup>	324 <sup>2</sup>	410 <sup>2</sup>	492 <sup>2</sup>	572 <sup>2</sup>	654 <sup>2</sup>	732 <sup>2</sup>	810 <sup>2</sup>	882 <sup>2</sup>	932 <sup>2</sup>	995 <sup>2</sup>	1060 <sup>2</sup>
	RPM	104 <sup>2</sup>	104 <sup>2</sup>	103 <sup>2</sup>	103 <sup>2</sup>	102 <sup>2</sup>	103 <sup>2</sup>	104 <sup>2</sup>	103 <sup>2</sup>	101 <sup>2</sup>	99 <sup>2</sup>	99 <sup>2</sup>	99 <sup>2</sup>	97 <sup>2</sup>	97 <sup>2</sup>
45	Nm	54 <sup>2</sup>	131 <sup>2</sup>	233 <sup>2</sup>	320 <sup>2</sup>	402 <sup>2</sup>	485 <sup>2</sup>	566 <sup>2</sup>	645 <sup>2</sup>	723 <sup>2</sup>	800 <sup>2</sup>	872 <sup>2</sup>	930 <sup>2</sup>	980 <sup>2</sup>	1060 <sup>2</sup>
	RPM	120 <sup>2</sup>	120 <sup>2</sup>	121 <sup>2</sup>	119 <sup>2</sup>	120 <sup>2</sup>	120 <sup>2</sup>	119 <sup>2</sup>	119 <sup>2</sup>	118 <sup>2</sup>	117 <sup>2</sup>	117 <sup>2</sup>	116 <sup>2</sup>	116 <sup>2</sup>	115 <sup>2</sup>

395cm<sup>3</sup>/r

	$\Delta$ Bar	17	34	52	69	86	103	121	138	155	172	190	205	224	241
LPM															
7.6	Nm	88 <sup>1</sup>	183 <sup>1</sup>	275 <sup>1</sup>	365 <sup>1</sup>	455 <sup>1</sup>	546 <sup>1</sup>	638 <sup>1</sup>	726 <sup>1</sup>	814 <sup>1</sup>	893 <sup>1</sup>	972 <sup>1</sup>	1043 <sup>2</sup>	1106 <sup>2</sup>	
	RPM	18 <sup>1</sup>	17 <sup>1</sup>	17 <sup>1</sup>	16 <sup>1</sup>	16 <sup>1</sup>	16 <sup>1</sup>	17 <sup>1</sup>	16 <sup>1</sup>	15 <sup>1</sup>	15 <sup>1</sup>	15 <sup>1</sup>	14 <sup>2</sup>	13 <sup>2</sup>	
15	Nm	87 <sup>1</sup>	186 <sup>1</sup>	280 <sup>1</sup>	371 <sup>1</sup>	462 <sup>1</sup>	549 <sup>1</sup>	634 <sup>1</sup>	718 <sup>1</sup>	802 <sup>1</sup>	885 <sup>1</sup>	967 <sup>1</sup>	1048 <sup>2</sup>	1128 <sup>2</sup>	1155 <sup>2</sup>
	RPM	37 <sup>1</sup>	37 <sup>1</sup>	36 <sup>1</sup>	35 <sup>1</sup>	33 <sup>1</sup>	33 <sup>1</sup>	35 <sup>1</sup>	36 <sup>1</sup>	36 <sup>1</sup>	35 <sup>1</sup>	35 <sup>1</sup>	34 <sup>2</sup>	34 <sup>2</sup>	33 <sup>2</sup>
23	Nm	84 <sup>1</sup>	182 <sup>1</sup>	278 <sup>1</sup>	370 <sup>1</sup>	461 <sup>1</sup>	549 <sup>1</sup>	637 <sup>1</sup>	721 <sup>1</sup>	802 <sup>1</sup>	882 <sup>1</sup>	962 <sup>1</sup>	1042 <sup>2</sup>	1121 <sup>2</sup>	1160 <sup>2</sup>
	RPM	57 <sup>1</sup>	57 <sup>1</sup>	55 <sup>1</sup>	54 <sup>1</sup>	52 <sup>1</sup>	51 <sup>1</sup>	50 <sup>1</sup>	51 <sup>1</sup>	53 <sup>1</sup>	54 <sup>1</sup>	55 <sup>1</sup>	54 <sup>2</sup>	53 <sup>2</sup>	53 <sup>2</sup>
30	Nm	79 <sup>1</sup>	176 <sup>1</sup>	274 <sup>1</sup>	367 <sup>1</sup>	459 <sup>1</sup>	548 <sup>1</sup>	637 <sup>1</sup>	722 <sup>1</sup>	805 <sup>1</sup>	883 <sup>1</sup>	960 <sup>1</sup>	1038 <sup>2</sup>	1116 <sup>2</sup>	1165 <sup>2</sup>
	RPM	75 <sup>1</sup>	75 <sup>1</sup>	75 <sup>1</sup>	74 <sup>1</sup>	72 <sup>1</sup>	70 <sup>1</sup>	68 <sup>1</sup>	67 <sup>1</sup>	69 <sup>1</sup>	72 <sup>1</sup>	74 <sup>1</sup>	74 <sup>2</sup>	74 <sup>2</sup>	73 <sup>2</sup>
38	Nm	71 <sup>2</sup>	168 <sup>2</sup>	265 <sup>2</sup>	359 <sup>2</sup>	453 <sup>2</sup>	544 <sup>2</sup>	635 <sup>2</sup>	722 <sup>2</sup>	806 <sup>2</sup>	887 <sup>2</sup>	962 <sup>2</sup>	1032 <sup>2</sup>	1104 <sup>2</sup>	1179 <sup>2</sup>
	RPM	95 <sup>2</sup>	95 <sup>2</sup>	95 <sup>2</sup>	93 <sup>2</sup>	91 <sup>2</sup>	90 <sup>2</sup>	87 <sup>2</sup>	85 <sup>2</sup>	83 <sup>2</sup>	83 <sup>2</sup>	88 <sup>2</sup>	93 <sup>2</sup>	93 <sup>2</sup>	93 <sup>2</sup>
45	Nm	63 <sup>2</sup>	159 <sup>2</sup>	256 <sup>2</sup>	349 <sup>2</sup>	440 <sup>2</sup>	529 <sup>2</sup>	618 <sup>2</sup>	703 <sup>2</sup>	788 <sup>2</sup>	870 <sup>2</sup>	950 <sup>2</sup>	1025 <sup>2</sup>	1093 <sup>2</sup>	1170 <sup>2</sup>
	RPM	113 <sup>2</sup>	113 <sup>2</sup>	113 <sup>2</sup>	113 <sup>2</sup>	111 <sup>2</sup>	109 <sup>2</sup>	107 <sup>2</sup>	105 <sup>2</sup>	105 <sup>2</sup>	100 <sup>2</sup>	100 <sup>2</sup>	105 <sup>2</sup>	110 <sup>2</sup>	113 <sup>2</sup>

A-Delta Series Housing

9/16-18 UNF

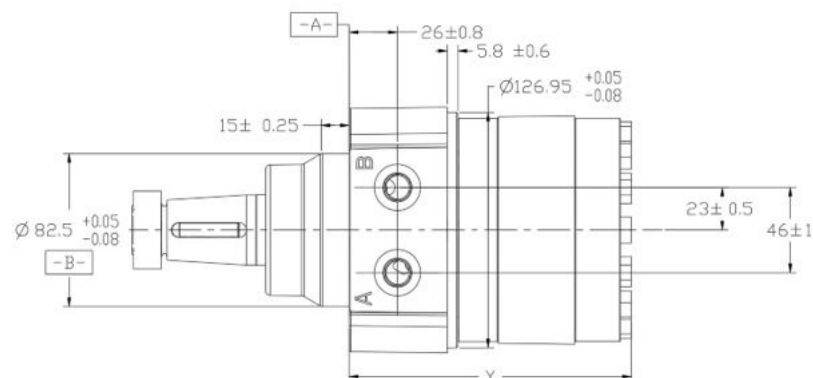

Ports:

**A-Delta Series**

Code: AC G 1/2 BSP Straight thread ports

Code: AG .5625-18 UNF-2B SAE O-ring port

**Standard rotation viewed from shaft end:**

Port A Pressurized - CCW

Port B Pressurized - CW

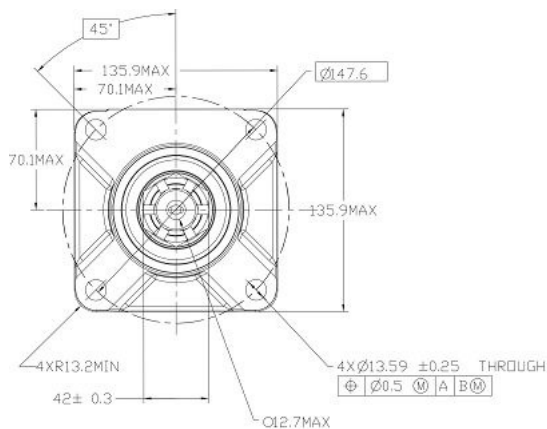

Displacement/cc	Y/mm
146	136.4
198	144.9
252	153.4
300	150.6
347	156.7
375	158.7
395	162.8

The stated dimensions are without paint. Paint thickness is 0.04~0.10mm.

**A-Delta Series Shaft Side Load Capacity**

The bearing curve represents allowable bearing loads based on ISO 281 bearing capacity for an L10 life of 2,000 hours at 100 rpm.

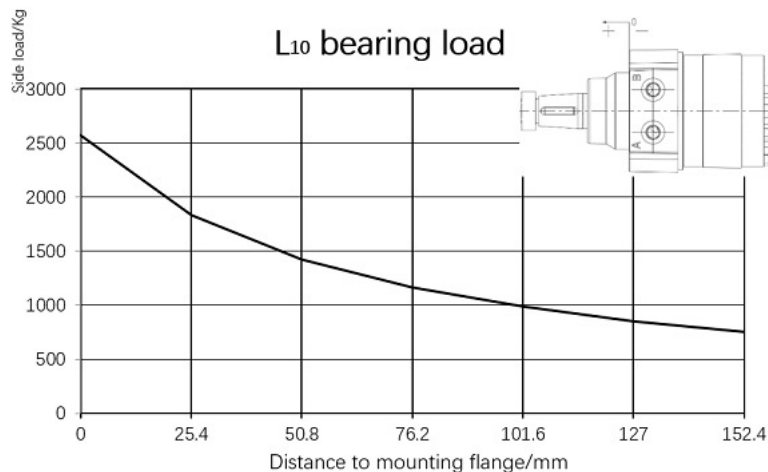

## A-Delta Series

### A-Delta Series Output Shaft

#### 37.82mm Taper shaft per SAE J501

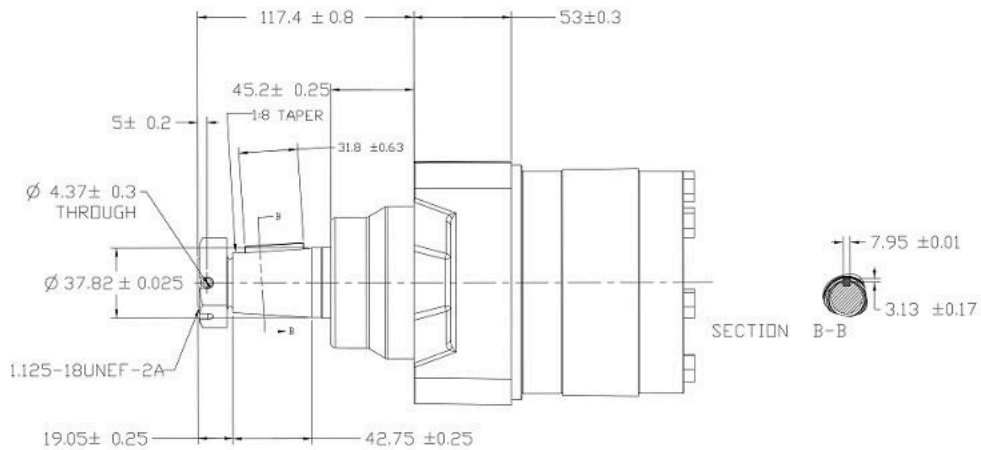

The state dimensions are without paint. Paint thickness is 0.04~0.10mm.

### A-Delta Series Ordering Information

#### POS 1 - Product

M Motor

#### POS 2, 3, 4 - Series

CDL A-Delta Series

#### POS 5, 6, 7 - Displacement

**146** 146cm<sup>3</sup>/r

**198** 198cm<sup>3</sup>/r

**252** 252cm<sup>3</sup>/r

**300** 300cm<sup>3</sup>/r

**347** 347cm<sup>3</sup>/r

**375** 362.9cm<sup>3</sup>/r

**395** 395cm<sup>3</sup>/r

#### POS 8, 9 - Mounting Description

**WQ** Wheel, 4 bolt: 82.6mm pilot height 15mm, 13.59 dia. holes on 147.6mm dia. bolt circle. 127.0mm dia. rear mount pilot, 53mm flange thickness

#### POS 10, 11 - Output Shaft Description

**70** 37.82mm dia. tapered shaft per SAE J501 with 1.125-18 UNEF-2A threaded shaft end and slotted hex nut, 7.938mm SQ X 31.75mm key, bearing position dia. 38.1mm

#### POS 12, 13 - Port Description

**AC** G 1/2 BSP straight thread ports

**AG** .5625-18 UNF-2B SAE O-ring port

## A-Delta Series

### **POS 14 - Pressure/Flow Option**

**0** None

### **POS 15 - Geroler Option**

**E** Reduced side clearance

### **POS 16 - Seal Option**

**0** Standard

### **POS 17, 18 - Accessories**

**00** None

### **POS 19, 20 - Special Features (Hardware)**

**00** None

**03** Low noise valve plate

**50** Valve plate with thrust bearing

### **POS 21, 22 - Special Features (Assembly)**

**00** None

**01** Reverse rotation

### **POS 23, 24 - Plant/Packaging**

**AB** Primer low gloss black, except output shaft (including dust ring), other positions need to be painted

### **POS 25, 26 - Customer Identification**

**00** None

### **POS 27 - Design Code**

**A** Two (2)

### **Example Model Code:**

MCDL198WQ70AG0E0000300AB00A

## A-Delta Series

### A-Delta Series Recommended Code Numbers

<b>Part numbers</b>	<b>Model code</b>
636AG00080A	MCDL198WQ70AG0E0000300AB00A
636AG00081A	MCDL300WQ70AG0E0000300AB00A
636AG00083A	MCDL395WQ70AG0E0000300AB00A
636AG00087A	MCDL375WQ70AG0E0000300AB00A
636AG00088A	MCDL252WQ70AG0E0000300AB00A
636AG00082A	MCDL347WQ70AG0E0000300AB00A
636AG00100A	MCDL146WQ70AG0E0000000AB00A
636AG00101A	MCDL176WQ70AG0E0000000AB00A
636AG00102A	MCDL300WQ70AG0E0000000AB00A
636AG00103A	MCDL252WQ70AG0E0000301AB00A

### Products we offer:

- Cartridge valves
- DCV directional control valves
- Electric converters
- Electric machines
- Electric motors
- Gear motors
- Gear pumps
- Hydraulic integrated circuits (HICs)
- Hydrostatic motors
- Hydrostatic pumps
- Orbital motors
- PLUS+1® controllers
- PLUS+1® displays
- PLUS+1® joysticks and pedals
- PLUS+1® operator interfaces
- PLUS+1® sensors
- PLUS+1® software
- PLUS+1® software services, support and training
- Position controls and sensors
- PVG proportional valves
- Steering components and systems
- Telematics

**Danfoss Power Solutions** is a global manufacturer and supplier of high-quality hydraulic and electric components. We specialize in providing state-of-the-art technology and solutions that excel in the harsh operating conditions of the mobile off-highway market as well as the marine sector. Building on our extensive applications expertise, we work closely with you to ensure exceptional performance for a broad range of applications. We help you and other customers around the world speed up system development, reduce costs and bring vehicles and vessels to market faster.

Danfoss Power Solutions – your strongest partner in mobile hydraulics and mobile electrification.

### Go to [www.danfoss.com](http://www.danfoss.com) for further product information.

We offer you expert worldwide support for ensuring the best possible solutions for outstanding performance. And with an extensive network of Global Service Partners, we also provide you with comprehensive global service for all of our components.

Local address:

### Hydro-Gear

[www.hydro-gear.com](http://www.hydro-gear.com)

### Daikin-Sauer-Danfoss

[www.daikin-sauer-danfoss.com](http://www.daikin-sauer-danfoss.com)

**Danfoss  
Power Solutions (US) Company**  
2800 East 13th Street  
Ames, IA 50010, USA  
Phone: +1 515 239 6000

**Danfoss  
Power Solutions GmbH & Co. OHG**  
Krokamp 35  
D-24539 Neumünster, Germany  
Phone: +49 4321 871 0

**Danfoss  
Power Solutions ApS**  
Nordborgvej 81  
DK-6430 Nordborg, Denmark  
Phone: +45 7488 2222

**Danfoss  
Power Solutions Trading  
(Shanghai) Co., Ltd.**  
Building #22, No. 1000 Jin Hai Rd  
Jin Qiao, Pudong New District  
Shanghai, China 201206  
Phone: +86 21 2080 6201

Danfoss can accept no responsibility for possible errors in catalogues, brochures and other printed material. Danfoss reserves the right to alter its products without notice. This also applies to products already on order provided that such alterations can be made without subsequent changes being necessary in specifications already agreed. All trademarks in this material are property of the respective companies. Danfoss and the Danfoss logotype are trademarks of Danfoss A/S. All rights reserved.