

OVERVIEW

The WR Series motors incorporate the latest advances for smooth performance, efficiency and durability. Featuring an optimized rotor geometry with seven precision rollers to eliminate sliding friction and provide rolling contact between the rotor and stator, thus increasing motor efficiency. A three-zone spool valve, integral check valves and a provision for a case drain reduce pressure on internal seals to improve product life. A wide variety of mounting, shaft, motor displacement and porting options are available to meet all application needs.

FEATURES / BENEFITS

- A variety of mounts and shafts provides flexibility in application design.
- A high-pressure shaft seal offers superior seal life and performance.
- The spool valve design gives superior performance and smooth operation over a wide speed and torque range.
- Built-in check valves (not shown) in the housing offer versatility and increased seal life.
- Optimized rotor geometry provides a smooth running and highly efficient product.

TYPICAL APPLICATIONS

conveyors, carwashes, positioners, light-duty wheel drives, sweepers, food processing, grain augers, spreaders, feed rollers, screw drives, brush drives and more

SERIES DESCRIPTIONS

251/252 - Hydraulic Motor
Standard

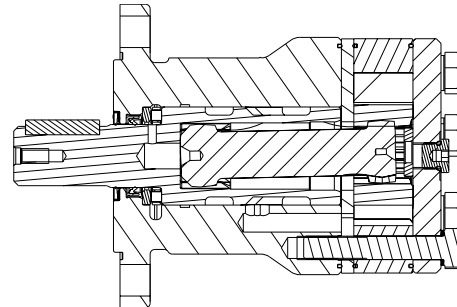

255/256 - Hydraulic Motor
Standard

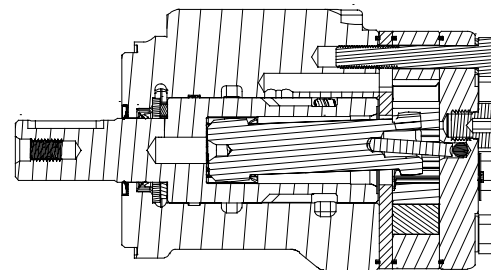

SPECIFICATIONS

CODE	Displacement cm ³ [in ³ /rev]	Max. Speed rpm		Max. Flow lpm [gpm]		Max. Torque Nm [lb-in]		Max. Pressure bar [psi]		
		cont.	inter.	cont.	inter.	cont.	inter.	cont.	inter.	peak
040	40 [2.5]	1116	1515	45 [12]	61 [16]	93 [823]	123 [1088]	155 [2250]	207 [3000]	224 [3250]
050	50 [3.1]	1058	1220	53 [14]	61 [16]	111 [982]	149 [1319]	155 [2250]	207 [3000]	224 [3250]
060	59 [3.6]	890	1142	53 [14]	68 [18]	138 [1221]	172 [1522]	155 [2250]	207 [3000]	224 [3250]
070	71 [4.3]	865	1078	61 [16]	76 [20]	176 [1558]	207 [1832]	172 [2500]	207 [3000]	241 [3500]
080	79 [4.9]	759	957	61 [16]	76 [20]	202 [1788]	243 [2150]	172 [2500]	207 [3000]	241 [3500]
090	88 [5.4]	691	864	61 [16]	76 [20]	222 [1965]	263 [2327]	172 [2500]	207 [3000]	241 [3500]
100	100 [6.1]	610	760	61 [16]	76 [20]	246 [2177]	289 [2558]	172 [2500]	207 [3000]	241 [3500]
115	113 [6.9]	539	672	61 [16]	76 [20]	284 [2513]	327 [2894]	172 [2500]	207 [3000]	241 [3500]
130	129 [7.9]	472	588	61 [16]	76 [20]	316 [2797]	375 [3319]	172 [2500]	207 [3000]	241 [3500]
160	160 [9.8]	379	469	61 [16]	76 [20]	400 [3540]	454 [4018]	172 [2500]	207 [3000]	241 [3500]
200	198 [12.1]	308	384	61 [16]	76 [20]	462 [4088]	544 [4814]	172 [2500]	207 [3000]	241 [3500]
240	236 [14.4]	249	315	61 [16]	76 [20]	548 [4850]	642 [5682]	172 [2500]	207 [3000]	224 [3250]
250	250 [15.3]	250	300	61 [16]	76 [20]	561 [4965]	624 [5522]	172 [2500]	207 [3000]	224 [3250]
290	291 [17.8]	210	256	61 [16]	76 [20]	526 [4655]	664 [5876]	138 [2000]	190 [2750]	207 [3000]
320	322 [19.6]	188	235	61 [16]	76 [20]	518 [4584]	690 [6106]	121 [1750]	172 [2500]	190 [2750]
400	400 [24.4]	152	190	61 [16]	76 [20]	551 [4873]	698 [6177]	104 [1500]	138 [2000]	155 [2250]

► Performance data is typical. Performance of production units varies slightly from one motor to another. Running at intermittent ratings should not exceed 10% of every minute of operation.

DISPLACEMENT PERFORMANCE

		Pressure - bar [psi]										Max. Cont.	Max. Inter.	
040		17 [250]	35 [500]	52 [750]	69 [1000]	86 [1250]	104 [1500]	121 [1750]	138 [2000]	155 [2250]	172 [2500]	207 [3000]		
40 cm ³ [2.5 in ³] / rev		Torque - Nm [lb-in], Speed rpm										Intermittent Ratings - 10% of Operation		
Flow - lpm [gpm]	2 [0.5]	9 [80] 43	20 [177] 40	32 [283] 35	40 [354] 29	37 [327] 24								50
	4 [1]	10 [88] 95	21 [186] 91	30 [265] 82	42 [372] 73	52 [460] 62	62 [549] 51							100
	8 [2]	9 [80] 188	19 [168] 180	28 [248] 170	41 [363] 160	51 [451] 144	64 [566] 137	72 [637] 126	79 [699] 115	89 [788] 102	99 [876] 88			199
	15 [4]	7 [62] 365	18 [159] 355	27 [239] 343	40 [354] 324	49 [434] 312	62 [549] 295	73 [646] 293	83 [735] 275	93 [823] 257	102 [903] 237	121 [1071] 198		373
	23 [6]	6 [53] 560	17 [150] 548	26 [230] 532	39 [345] 515	48 [425] 502	61 [540] 485	70 [619] 471	82 [726] 451	90 [796] 432	101 [894] 444	122 [1080] 398		572
	30 [8]	6 [53] 728	16 [142] 716	25 [221] 706	37 [327] 684	47 [416] 667	59 [522] 648	68 [602] 634	81 [717] 629	88 [779] 618	99 [876] 601	123 [1088] 545		746
	38 [10]	5 [44] 942	14 [124] 936	22 [195] 927	35 [310] 918	45 [398] 904	57 [504] 890	68 [602] 874	78 [690] 852	86 [761] 835	97 [858] 812	118 [1044] 743		945
	45 [12]	3 [27] 1116	13 [115] 1113	21 [186] 1100	34 [301] 1082	43 [381] 1056	55 [487] 1028	67 [593] 1004	77 [681] 976	84 [743] 952	95 [841] 916	116 [1027] 870		1119
	53 [14]		10 [88] 1316	20 [177] 1301	31 [274] 1278	39 [345] 1253	52 [460] 1230	63 [558] 1206	75 [664] 1184	82 [726] 1154	93 [823] 1116	115 [1018] 1078		1318
	61 [16]		8 [71] 1515	19 [168] 1497	29 [257] 1469	38 [336] 1442	49 [434] 1415	60 [531] 1399	74 [655] 1378	80 [708] 1355	90 [796] 1330	113 [1000] 1298		1517
Max. Cont.														
Max. Inter.														
Rotor Width		Overall Efficiency - 70 - 100% <input type="checkbox"/> 40 - 69% <input type="checkbox"/> 0 - 39% <input checked="" type="checkbox"/>												
8.1 [3.17]		Theoretical Torque - Nm [lb-in]												
mm [in]		11 [97]	22 [195]	34 [301]	45 [398]	56 [496]	67 [593]	78 [690]	90 [796]	101 [894]	112 [991]	132 [1167]		
		Displacement tested at 54°C [129°F] with an oil viscosity of 46cSt [213 SUS]												

		Pressure - bar [psi]										Max. Cont.	Max. Inter.	
050		17 [250]	35 [500]	52 [750]	69 [1000]	86 [1250]	104 [1500]	121 [1750]	138 [2000]	155 [2250]	172 [2500]	207 [3000]		
50 cm ³ [3.1 in ³] / rev		Torque - Nm [lb-in], Speed rpm										Intermittent Ratings - 10% of Operation		
Flow - lpm [gpm]	4 [1]	11 [97] 77	24 [212] 75	37 [327] 74	49 [434] 69	61 [540] 63	74 [655] 52	82 [726] 41	91 [805] 36					80
	8 [2]	11 [97] 155	24 [212] 152	36 [319] 150	49 [434] 142	62 [548] 132	75 [664] 124	88 [779] 107	99 [876] 91	107 [947] 82				160
	15 [4]	9 [80] 295	23 [204] 291	36 [319] 283	49 [434] 272	62 [548] 267	75 [664] 248	88 [779] 231	99 [876] 215	110 [973] 199	123 [1088] 182	147 [1301] 164		300
	23 [6]	7 [62] 452	22 [195] 447	35 [310] 434	47 [416] 430	61 [540] 416	74 [655] 402	87 [770] 385	99 [876] 368	111 [982] 346	124 [1097] 324	149 [1319] 300		460
	30 [8]	5 [44] 594	21 [186] 589	34 [301] 577	45 [398] 566	60 [531] 546	74 [655] 528	86 [761] 509	99 [876] 489	111 [982] 468	125 [1106] 448	148 [1310] 426		600
	38 [10]	3 [27] 754	19 [168] 749	32 [283] 736	45 [398] 728	57 [504] 716	70 [619] 699	82 [726] 680	95 [841] 664	107 [947] 644	120 [1062] 624	142 [1257] 600		760
	45 [12]	2 [18] 896	17 [150] 892	30 [265] 875	43 [381] 873	55 [487] 861	68 [602] 843	80 [708] 827	92 [814] 812	105 [929] 794	116 [1027] 776	138 [1221] 752		900
	53 [14]		14 [124] 1058	27 [239] 1055	39 [345] 1052	51 [451] 1036	64 [566] 998	76 [673] 988	88 [779] 960	100 [885] 972	112 [991] 904	134 [1186] 860		1060
	61 [16]		11 [97] 1220	24 [212] 1216	35 [310] 1212	47 [416] 1210	60 [531] 1198	72 [637] 1160	84 [743] 1130	96 [850] 1112	108 [956] 1080	130 [1150] 1032		1220
	Max. Cont.													
Max. Inter.														
Rotor Width		Overall Efficiency - 70 - 100% <input type="checkbox"/> 40 - 69% <input type="checkbox"/> 0 - 39% <input checked="" type="checkbox"/>												
9.9 [3.89]		Theoretical Torque - Nm [lb-in]												
mm [in]		14 [122]	27 [195]	41 [301]	55 [398]	69 [496]	82 [593]	96 [690]	110 [796]	124 [894]	137 [1215]	165 [1458]		
		Displacement tested at 54°C [129°F] with an oil viscosity of 46cSt [213 SUS]												

► Performance data is typical. Performance of production units varies slightly from one motor to another. Operating at maximum continuous pressure and maximum continuous low simultaneously is not recommended. For additional information on product testing please refer to page 6.

DISPLACEMENT PERFORMANCE

		Pressure - bar [psi]								Max. Cont.	Max. Inter.		
060		17 [250]	35 [500]	52 [750]	69 [1000]	86 [1250]	104 [1500]	121 [1750]	138 [2000]	155 [2250]	172 [2500]	207 [3000]	
59 cm ³ [3.6 in ³] / rev		Torque - Nm [lb-in], Speed rpm											
		Intermittent Ratings - 10% of Operation											
Flow - lpm [gpm]	2 [0.5]	12 [106] 28	26 [230] 22	34 [301] 15	45 [398] 12							34	
	4 [1]	13 [115] 60	29 [257] 56	42 [372] 50	56 [496] 44	62 [549] 33	68 [602] 16					67	
	8 [2]	14 [124] 134	31 [274] 129	46 [407] 125	58 [513] 118	74 [655] 113	94 [832] 107	110 [974] 97	121 [1071] 87	137 [1212] 73	148 [1310] 58	168 [1487] 50	135
	15 [4]	12 [106] 250	30 [266] 245	45 [398] 240	60 [531] 232	75 [664] 225	95 [841] 217	108 [956] 208	122 [1080] 198	138 [1221] 185	150 [1328] 174	170 [1505] 168	253
	23 [6]	11 [97] 384	30 [266] 380	44 [389] 376	59 [522] 370	74 [655] 364	93 [823] 356	106 [938] 345	124 [1097] 331	138 [1221] 318	152 [1345] 307	172 [1522] 298	387
	30 [8]	10 [89] 502	29 [257] 496	43 [381] 494	58 [513] 490	72 [637] 485	92 [814] 478	104 [920] 468	123 [1089] 460	135 [1195] 450	148 [1310] 438	170 [1505] 431	505
	38 [10]	9 [80] 635	28 [248] 632	42 [372] 629	55 [487] 628	70 [620] 619	90 [797] 611	102 [903] 598	121 [1071] 589	133 [1177] 578	146 [1292] 561	168 [1487] 513	640
	45 [12]	8 [71] 755	24 [212] 748	39 [345] 745	52 [460] 741	69 [611] 735	87 [770] 729	100 [885] 718	118 [1044] 705	130 [1151] 688	145 [1283] 676	164 [1451] 659	758
	53 [14]	6 [53] 890	23 [204] 888	38 [336] 884	48 [425] 880	65 [575] 874	84 [743] 865	98 [867] 852	114 [1009] 840	127 [1124] 831	138 [1221] 820	162 [1434] 802	892
	Max. Cont.	61 [16]	17 [150] 1021	29 [257] 1018	44 [389] 1011	62 [549] 1007	78 [690] 1000	90 [797] 993	106 [938] 984	121 [1071] 974	136 [1204] 962	160 [1416] 956	1026
Max. Inter.	68 [18]	10 [89] 1142	26 [230] 1140	40 [354] 1129	57 [504] 1112	73 [646] 1097	86 [761] 1085	102 [903] 1074	115 [1018] 1060	130 [1151] 1044	158 [1398] 1020	1145	
Rotor Width		Overall Efficiency - 70 - 100% <input type="checkbox"/> 40 - 69% <input type="checkbox"/> 0 - 39% <input type="checkbox"/>											
Theoretical Torque - Nm [lb-in]		Theoretical Torque - Nm [lb-in]											
11.8 [463]		16 [142] 33 [292] 49 [434] 65 [575] 81 [717] 98 [867] 114 [1009] 131 [1150] 147 [1292] 164 [1442] 179 [1584]											
mm [in]		Displacement tested at 54°C [129°F] with an oil viscosity of 46cSt [213 SUS]											

		Pressure - bar [psi]								Max. Cont.	Max. Inter.		
070		17 [250]	35 [500]	69 [1000]	86 [1250]	104 [1500]	121 [1750]	138 [2000]	155 [2250]	172 [2500]	190 [2750]	207 [3000]	
71 cm ³ [4.3 in ³] / rev		Torque - Nm [lb-in], Speed rpm											
		Intermittent Ratings - 10% of Operation											
Flow - lpm [gpm]	2 [0.5]	13 [115] 26	30 [266] 23									28	
	4 [1]	14 [124] 55	32 [283] 50	66 [584] 40	73 [646] 34							57	
	8 [2]	16 [142] 112	34 [301] 106	70 [620] 94	88 [779] 89	104 [920] 81	120 [1062] 73	134 [1186] 66	149 [1319] 51			113	
	15 [4]	15 [133] 211	33 [292] 206	71 [628] 194	87 [770] 186	107 [947] 178	123 [1089] 172	139 [1230] 163	158 [1398] 152	171 [1513] 143	196 [1735] 125	211 [1867] 110	213
	23 [6]	14 [124] 324	31 [274] 319	66 [584] 306	83 [735] 298	104 [920] 288	124 [1097] 280	138 [1221] 270	157 [1389] 260	176 [1558] 248	192 [1699] 232	207 [1832] 221	326
	30 [8]	13 [115] 425	30 [266] 418	67 [593] 403	84 [743] 394	104 [920] 386	123 [1089] 376	137 [1212] 364	159 [1407] 350	174 [1540] 339	193 [1708] 326	203 [1797] 312	426
	38 [10]	10 [89] 539	29 [257] 537	65 [575] 529	82 [726] 520	103 [903] 508	115 [1018] 500	135 [1195] 486	152 [1345] 474	172 [1522] 458	186 [1646] 440	204 [1805] 425	539
	45 [12]	7 [62] 638	25 [221] 634	63 [558] 622	82 [726] 614	98 [867] 604	117 [1035] 594	132 [1168] 578	152 [1345] 566	169 [1496] 552	189 [1673] 538	199 [1761] 522	638
	53 [14]	5 [44] 752	21 [186] 751	58 [513] 743	75 [664] 736	94 [832] 728	115 [1018] 718	131 [1159] 705	147 [1301] 690	167 [1478] 675	187 [1655] 650	204 [1805] 630	752
	Max. Cont.	61 [16]	17 [150] 865	54 [478] 854	73 [646] 843	91 [805] 831	107 [947] 818	128 [1133] 807	143 [1266] 795	160 [1416] 782	177 [1566] 766	194 [1717] 750	865
Max. Inter.	76 [20]	16 [142] 965	48 [425] 960	70 [620] 956	88 [779] 945	106 [938] 932	122 [1080] 920	139 [1230] 902	156 [1381] 888	173 [1531] 876	191 [1690] 850	965	
Rotor Width		Overall Efficiency - 70 - 100% <input type="checkbox"/> 40 - 69% <input type="checkbox"/> 0 - 39% <input type="checkbox"/>											
Theoretical Torque - Nm [lb-in]		Theoretical Torque - Nm [lb-in]											
13.8 [542]		19 [169] 39 [348] 77 [685] 97 [854] 117 [1033] 136 [1202] 155 [1371] 174 [1540] 194 [1719] 213 [1888] 232 [2056]											
mm [in]		Displacement tested at 54°C [129°F] with an oil viscosity of 46cSt [213 SUS]											

► Performance data is typical. Performance of production units varies slightly from one motor to another. Operating at maximum continuous pressure and maximum continuous low simultaneously is not recommended. For additional information on product testing please refer to page 6.

DISPLACEMENT PERFORMANCE

		Pressure - bar [psi]										Max. Cont.	Max. Inter.	
080		17 [250]	35 [500]	69 [1000]	86 [1250]	104 [1500]	121 [1750]	138 [2000]	155 [2250]	172 [2500]	190 [2750]	207 [3000]		
79 cm ³ [4.9 in ³] / rev		Torque - Nm [lb-in], Speed rpm										Intermittent Ratings - 10% of Operation		
Flow - lpm [gpm]	4 [1]	18 [159] 49	38 [336] 46	77 [681] 41	94 [832] 40									50
	8 [2]	18 [159] 99	39 [345] 98	76 [673] 89	98 [867] 83	120 [1062] 74	141 [1248] 68	159 [1407] 59	174 [1540] 50					100
	15 [4]	17 [150] 189	38 [336] 187	76 [673] 177	98 [867] 170	120 [1062] 161	141 [1248] 151	160 [1416] 144	180 [1593] 131	199 [1761] 122	220 [1947] 112	240 [2124] 100		190
	23 [6]	17 [150] 290	37 [327] 286	79 [690] 274	97 [858] 268	119 [1053] 259	140 [1239] 250	160 [1416] 240	182 [1611] 227	202 [1788] 214	222 [1965] 200	243 [2150] 185		291
	30 [8]	14 [124] 374	35 [310] 368	75 [664] 357	96 [850] 349	117 [1035] 339	138 [1221] 330	159 [1407] 321	181 [1602] 307	200 [1770] 296	220 [1947] 284	241 [2133] 268		380
	38 [10]	11 [97] 480	34 [301] 475	73 [646] 464	94 [832] 453	116 [1027] 442	138 [1221] 433	158 [1398] 423	177 [1566] 412	199 [1761] 398	218 [1929] 383	238 [2106] 370		481
	45 [12]	8 [71] 568	31 [274] 562	72 [637] 548	93 [823] 543	114 [1009] 532	135 [1195] 525	155 [1372] 515	176 [1558] 501	196 [1735] 486	215 [1903] 472	235 [2080] 458		570
	53 [14]	5 [44] 668	28 [248] 663	69 [611] 649	90 [796] 642	111 [982] 632	133 [1177] 624	152 [1345] 620	172 [1522] 600	193 [1708] 585	212 [1876] 570	232 [2053] 554		671
	61 [16]		24 [212] 759	65 [575] 752	85 [752] 747	109 [965] 731	129 [1142] 722	148 [1310] 710	168 [1487] 703	187 [1655] 689	208 [1841] 675	228 [2018] 660		772
	68 [18]		21 [186] 855	61 [540] 848	81 [717] 842	105 [929] 828	125 [1106] 818	143 [1265] 807	164 [1451] 800	182 [1611] 789	204 [1805] 776	223 [1973] 760		861
76 [20]		18 [159] 957	56 [496] 952	76 [673] 944	100 [885] 932	120 [1062] 923	138 [1221] 912	159 [1407] 900	178 [1575] 886	199 [1761] 872	218 [1929] 858		962	
Rotor Width		Overall Efficiency - 70 - 100% <input type="checkbox"/> 40 - 69% <input type="checkbox"/> 0 - 39% <input checked="" type="checkbox"/>												
15.7 [617] mm [in]		Theoretical Torque - Nm [lb-in]												
		22 [192]	43 [384]	87 [768]	108 [960]	130 [1152]	152 [1344]	174 [1536]	195 [1728]	217 [1920]	239 [2112]	260 [2304]		
		Displacement tested at 54°C [129°F] with an oil viscosity of 46cSt [213 SUS]												

		Pressure - bar [psi]										Max. Cont.	Max. Inter.	
090		17 [250]	35 [500]	69 [1000]	86 [1250]	104 [1500]	121 [1750]	138 [2000]	155 [2250]	172 [2500]	190 [2750]	207 [3000]		
88 cm ³ [5.4 in ³] / rev		Torque - Nm [lb-in], Speed rpm										Intermittent Ratings - 10% of Operation		
Flow - lpm [gpm]	2 [0.5]	18 [159] 23	40 [354] 22	75 [664] 17										23
	4 [1]	20 [177] 45	44 [389] 42	88 [779] 35	112 [991] 31	118 [1044] 27	128 [1133] 21							45
	8 [2]	22 [195] 91	44 [389] 88	87 [770] 81	114 [1009] 77	134 [1186] 72	158 [1398] 68	175 [1549] 60	198 [1752] 52	216 [1912] 42				91
	15 [4]	20 [177] 169	44 [389] 166	88 [779] 160	112 [991] 156	134 [1186] 152	154 [1363] 146	182 [1611] 140	204 [1805] 130	222 [1965] 122	242 [2142] 110	262 [2319] 96		170
	23 [6]	19 [168] 260	40 [354] 257	86 [761] 250	110 [974] 245	131 [1159] 238	152 [1345] 232	176 [1558] 225	196 [1735] 215	218 [1929] 205	242 [2142] 193	263 [2327] 186		260
	30 [8]	17 [150] 339	38 [336] 336	83 [735] 328	108 [956] 324	126 [1115] 318	150 [1327] 308	173 [1531] 300	194 [1717] 292	216 [1912] 280	238 [2106] 270	258 [2283] 258		340
	38 [10]	14 [124] 430	33 [292] 429	77 [681] 426	106 [938] 424	122 [1080] 417	146 [1292] 411	170 [1504] 402	188 [1664] 393	210 [1858] 380	232 [2053] 366	253 [2239] 354		430
	45 [12]	9 [80] 510	30 [265] 508	73 [646] 504	103 [912] 500	120 [1062] 496	145 [1283] 488	164 [1451] 480	184 [1628] 472	206 [1823] 462	228 [2018] 448	246 [2177] 434		510
	53 [14]	5 [44] 601	25 [221] 600	69 [611] 596	97 [856] 594	114 [1009] 591	140 [1239] 586	160 [1416] 578	178 [1575] 566	202 [1788] 552	226 [2000] 540	244 [2159] 528		601
	61 [16]		20 [177] 691	66 [584] 688	90 [797] 684	109 [965] 678	134 [1186] 670	156 [1381] 664	173 [1531] 654	200 [1770] 642	220 [1947] 630	242 [2142] 610		692
68 [18]		16 [142] 772	63 [558] 770	84 [743] 768	105 [929] 766	128 [1133] 764	152 [1345] 754	168 [1487] 742	193 [1708] 722	214 [1894] 712	236 [2088] 700		772	
76 [20]		10 [88] 864	58 [513] 863	79 [699] 858	100 [885] 848	121 [1071] 844	148 [1310] 835	163 [1442] 825	186 [1646] 812	205 [1814] 800	226 [2000] 778		864	
Rotor Width		Overall Efficiency - 70 - 100% <input type="checkbox"/> 40 - 69% <input type="checkbox"/> 0 - 39% <input checked="" type="checkbox"/>												
17.3 [682] mm [in]		Theoretical Torque - Nm [lb-in]												
		24 [215]	49 [429]	97 [859]	121 [1073]	146 [1288]	170 [1502]	194 [1717]	218 [1932]	243 [2146]	267 [2361]	291 [2576]		
		Displacement tested at 54°C [129°F] with an oil viscosity of 46cSt [213 SUS]												

► Performance data is typical. Performance of production units varies slightly from one motor to another. Operating at maximum continuous pressure and maximum continuous low simultaneously is not recommended. For additional information on product testing please refer to page 6.

DISPLACEMENT PERFORMANCE

		Pressure - bar [psi]								Max. Cont.	Max. Inter.			
100		17 [250]	35 [500]	69 [1000]	86 [1250]	104 [1500]	121 [1750]	138 [2000]	155 [2250]	172 [2500]	190 [2750]	207 [3000]		
100 cm ³ [6.1 in ³] / rev		Torque - Nm [lb-in], Speed rpm										Intermittent Ratings - 10% of Operation		
Flow - lpm [gpm]	2 [0.5]	18 [159] 17	37 [327] 13	77 [681] 12	91 [805] 11									20
	4 [1]	26 [230] 38	49 [434] 37	84 [743] 33	106 [938] 31	120 [1062] 29	140 [1239] 15	160 [1416] 7						40
	8 [2]	25 [221] 80	50 [442] 78	98 [867] 75	125 [1106] 70	150 [1327] 68	175 [1549] 65	199 [1761] 61	189 [1673] 20					80
	15 [4]	26 [230] 150	46 [407] 148	97 [858] 142	124 [1097] 139	148 [1310] 136	175 [1549] 131	198 [1752] 128	224 [1982] 122	245 [2168] 118	267 [2363] 111	289 [2558] 85		150
	23 [6]	23 [203] 229	48 [425] 226	96 [850] 221	123 [1088] 218	148 [1310] 215	173 [1531] 212	200 [1770] 208	223 [1973] 201	246 [2177] 197	269 [2381] 189	286 [2531] 162		230
	30 [8]	21 [186] 296	45 [398] 292	93 [823] 285	121 [1071] 282	146 [1292] 280	168 [1487] 280	195 [1726] 274	221 [1956] 270	244 [2159] 265	265 [2345] 255	284 [2513] 208		300
	38 [10]	17 [150] 378	41 [363] 375	91 [805] 367	115 [1018] 370	141 [1248] 367	165 [1460] 364	189 [1673] 363	215 [1903] 361	238 [2106] 353	264 [2336] 338	282 [2496] 310		380
	45 [12]	14 [123] 450	36 [319] 448	89 [788] 442	116 [1027] 438	140 [1239] 433	162 [1434] 426	188 [1664] 420	210 [1858] 412	234 [2071] 404	258 [2283] 390	280 [2478] 355		450
	53 [14]	12 [106] 528	34 [301] 526	83 [735] 520	109 [965] 518	134 [1186] 514	158 [1389] 508	181 [1602] 500	205 [1814] 490	228 [2017] 480	256 [2265] 468	278 [2460] 440		530
	61 [16]	10 [88] 610	28 [248] 608	79 [699] 600	103 [912] 596	129 [1142] 590	152 [1345] 582	172 [1522] 576	198 [1752] 568	223 [1973] 556	254 [2248] 542	276 [2443] 525		610
68 [18]	6 [53] 680	21 [186] 677	71 [628] 666	94 [832] 660	121 [1071] 653	146 [1292] 645	169 [1496] 635	192 [1699] 624	215 [1903] 610	251 [2221] 594	272 [2407] 574		680	
76 [20]		15 [133] 760	63 [558] 754	85 [752] 750	112 [991] 742	133 [1177] 730	160 [1416] 715	185 [1637] 702	202 [1788] 688	248 [2195] 666	267 [2363] 636		760	
Rotor Width		Overall Efficiency - 70 - 100% <input type="checkbox"/> 40 - 69% <input type="checkbox"/> 0 - 39% <input type="checkbox"/>												
Theoretical Torque - Nm [lb-in]		27 [239] 56 [496] 110 [974] 137 [1212] 166 [1469] 193 [1708] 220 [1947] 247 [2186] 275 [2434] 303 [2682] 330 [2921]												
mm [in]		Displacement tested at 54°C [129°F] with an oil viscosity of 46cSt [213 SUS]												

		Pressure - bar [psi]								Max. Cont.	Max. Inter.			
115		17 [250]	35 [500]	69 [1000]	86 [1250]	104 [1500]	121 [1750]	138 [2000]	155 [2250]	172 [2500]	190 [2750]	207 [3000]		
113 cm ³ [6.9 in ³] / rev		Torque - Nm [lb-in], Speed rpm										Intermittent Ratings - 10% of Operation		
Flow - lpm [gpm]	2 [0.5]	23 [204] 17	53 [469] 12											18
	4 [1]	25 [221] 35	56 [496] 34	95 [841] 30	118 [1044] 19									35
	8 [2]	25 [221] 70	59 [522] 69	117 [1035] 65	144 [1274] 62	172 [1522] 60	202 [1788] 56							71
	15 [4]	24 [212] 130	58 [513] 129	112 [991] 127	144 [1274] 125	173 [1531] 122	202 [1788] 117	225 [1991] 114	251 [2221] 108					133
	23 [6]	22 [195] 200	51 [451] 199	111 [982] 197	140 [1239] 194	171 [1513] 191	201 [1779] 186	224 [1982] 183	251 [2221] 176	284 [2513] 170	307 [2717] 153			204
	30 [8]	21 [186] 264	53 [469] 262	108 [956] 258	134 [1186] 256	167 [1478] 254	196 [1735] 251	222 [1965] 248	251 [2221] 240	278 [2460] 232	305 [2699] 226	327 [2894] 210		265
	38 [10]	16 [142] 336	46 [407] 334	105 [929] 330	131 [1159] 326	164 [1451] 323	191 [1690] 318	217 [1920] 312	247 [2186] 306	271 [2398] 300	299 [2646] 292	327 [2894] 281		336
	45 [12]	12 [106] 397	43 [381] 396	101 [894] 390	132 [1168] 387	161 [1425] 382	187 [1655] 379	218 [1929] 371	239 [2115] 363	269 [2381] 355	290 [2566] 344	319 [2823] 339		398
	53 [14]	6 [53] 468	35 [310] 464	97 [858] 456	125 [1106] 452	157 [1389] 448	179 [1584] 444	207 [1832] 442	237 [2097] 436	259 [2292] 430	289 [2558] 422	315 [2788] 415		469
	61 [16]		34 [301] 539	90 [796] 534	118 [1044] 531	149 [1319] 524	174 [1540] 521	200 [1770] 518	233 [2062] 506	254 [2248] 498	285 [2522] 495	314 [2779] 479		540
68 [18]		29 [257] 601	84 [743] 596	114 [1009] 594	140 [1239] 589	172 [1522] 583	202 [1788] 572	221 [1956] 566	253 [2239] 557	282 [2496] 547	299 [2646] 544		602	
76 [20]		17 [150] 672	73 [646] 668	103 [912] 664	132 [1168] 658	161 [1425] 655	186 [1646] 648	214 [1894] 638	240 [2124] 627	266 [2354] 621	293 [2593] 607		673	
Rotor Width		Overall Efficiency - 70 - 100% <input type="checkbox"/> 40 - 69% <input type="checkbox"/> 0 - 39% <input type="checkbox"/>												
Theoretical Torque - Nm [lb-in]		31 [274] 62 [549] 124 [1097] 155 [1372] 186 [1646] 217 [1920] 248 [2195] 279 [2469] 310 [2743] 341 [3018] 372 [3292]												
mm [in]		Displacement tested at 54°C [129°F] with an oil viscosity of 46cSt [213 SUS]												

► Performance data is typical. Performance of production units varies slightly from one motor to another. Operating at maximum continuous pressure and maximum continuous low simultaneously is not recommended. For additional information on product testing please refer to page 6.

DISPLACEMENT PERFORMANCE

		Pressure - bar [psi]										Max. Cont.	Max. Inter.				
130		17 [250]	35 [500]	69 [1000]	86 [1250]	104 [1500]	121 [1750]	138 [2000]	155 [2250]	172 [2500]	190 [2750]	207 [3000]					
129 cm ³ [7.9 in ³] / rev		Torque - Nm [lb-in], Speed rpm											Intermittent Ratings - 10% of Operation				
Flow - lpm [gpm]	2 [0.5]	34 [301] 15	60 [531] 6														15
	4 [1]	32 [283] 30	64 [566] 29	124 [1097] 18	140 [1239] 10	185 [1637] 6											30
	8 [2]	31 [274] 59	65 [575] 58	126 [1115] 51	144 [1274] 46	198 [1752] 38	223 [1974] 32	248 [2195] 25									59
	15 [4]	31 [274] 115	66 [584] 112	130 [1151] 106	164 [1451] 102	195 [1726] 97	221 [1956] 92	255 [2257] 86	285 [2522] 80	312 [2761] 74	345 [3053] 66						118
	23 [6]	30 [266] 177	65 [575] 175	130 [1151] 167	162 [1434] 163	196 [1735] 157	230 [2036] 152	265 [2345] 142	289 [2558] 138	316 [2797] 132	352 [3115] 121	375 [3319] 114					177
	30 [8]	28 [248] 232	64 [566] 227	128 [1133] 218	157 [1389] 213	192 [1699] 208	223 [1974] 200	259 [2292] 189	284 [2513] 184	313 [2770] 176	343 [3036] 168	374 [3310] 162					235
	38 [10]	20 [177] 294	60 [531] 289	125 [1106] 280	157 [1389] 275	188 [1664] 268	222 [1965] 260	254 [2248] 251	282 [2496] 243	313 [2770] 234	349 [3089] 221	370 [3275] 214					294
	45 [12]	15 [133] 353	55 [487] 343	120 [1062] 343	152 [1345] 338	186 [1646] 331	216 [1912] 321	244 [2159] 311	281 [2487] 299	307 [2717] 289	341 [3018] 277	369 [3266] 264					353
	53 [14]	13 [115] 411	47 [416] 408	117 [1035] 398	150 [1328] 392	181 [1602] 386	212 [1876] 378	247 [2186] 366	273 [2416] 357	310 [2744] 347	335 [2965] 335	363 [3213] 325					411
	61 [16]	7 [62] 472	42 [372] 470	106 [938] 465	140 [1239] 462	170 [1505] 456	207 [1832] 447	239 [2115] 435	265 [2345] 426	296 [2620] 409	328 [2903] 396	361 [3195] 388					472
68 [18]		36 [319] 529	102 [903] 522	132 [1168] 517	166 [1469] 507	198 [1752] 500	224 [1982] 489	262 [2319] 482	292 [2584] 468	323 [2859] 445	351 [3106] 430					529	
76 [20]		32 [283] 588	94 [832] 585	123 [1089] 580	158 [1398] 570	190 [1682] 562	219 [1938] 550	254 [2248] 535	282 [2496] 520	308 [2726] 510	347 [3071] 490					588	
Rotor Width		Overall Efficiency - 70 - 100% <input type="checkbox"/> 40 - 69% <input type="checkbox"/> 0 - 39% <input type="checkbox"/>															
Theoretical Torque - Nm [lb-in]		Theoretical Torque - Nm [lb-in]															
25.4 [1.002] mm [in]		35 [310]	71 [628]	142 [1257]	177 [1566]	212 [1876]	248 [2195]	283 [2504]	318 [2814]	354 [3133]	389 [3442]	425 [3761]					
		Displacement tested at 54°C [129°F] with an oil viscosity of 46cSt [213 SUS]															

		Pressure - bar [psi]										Max. Cont.	Max. Inter.				
160		17 [250]	35 [500]	69 [1000]	86 [1250]	104 [1500]	121 [1750]	138 [2000]	155 [2250]	172 [2500]	190 [2750]	207 [3000]					
160 cm ³ [9.8 in ³] / rev		Torque - Nm [lb-in], Speed rpm											Intermittent Ratings - 10% of Operation				
Flow - lpm [gpm]	2 [0.5]	30 [266] 12	66 [584] 11	109 [965] 5													13
	4 [1]	32 [283] 24	70 [620] 23	136 [1204] 21	164 [1451] 20	182 [1611] 14	250 [2213] 6										25
	8 [2]	38 [336] 48	76 [673] 47	157 [1389] 42	181 [1602] 38	202 [1788] 34	265 [2345] 28	290 [2567] 22									50
	15 [4]	39 [345] 92	78 [690] 89	166 [1469] 84	205 [1814] 82	242 [2142] 77	275 [2434] 73	317 [2805] 70	358 [3169] 67	400 [3540] 62							94
	23 [6]	40 [354] 140	79 [699] 137	160 [1416] 132	203 [1797] 128	246 [2177] 123	290 [2567] 118	320 [2832] 114	354 [3133] 110	396 [3505] 106	404 [3575] 100	440 [3894] 94					144
	30 [8]	34 [301] 184	73 [646] 178	164 [1451] 172	200 [1770] 170	245 [2168] 164	288 [2549] 160	316 [2797] 152	350 [3098] 147	388 [3434] 142	428 [3788] 134	448 [3965] 129					188
	38 [10]	32 [283] 235	72 [637] 230	156 [1381] 222	196 [1735] 218	240 [2124] 212	282 [2496] 208	312 [2761] 200	347 [3071] 192	389 [3443] 184	422 [3735] 178	454 [4018] 172					238
	45 [12]	24 [212] 278	70 [620] 272	151 [1336] 264	192 [1699] 259	236 [2089] 253	278 [2460] 247	310 [2744] 242	344 [3044] 235	382 [3381] 227	419 [3708] 216	450 [3983] 210					281
	53 [14]	20 [177] 327	60 [531] 322	144 [1274] 312	186 [1646] 306	232 [2053] 300	266 [2354] 295	306 [2708] 289	338 [2991] 281	374 [3310] 276	420 [3717] 267	448 [3965] 258					331
	61 [16]	12 [106] 379	52 [460] 374	134 [1186] 360	178 [1575] 355	218 [1929] 350	254 [2248] 342	297 [2628] 338	334 [2956] 333	371 [3283] 323	401 [3549] 316	442 [3912] 308					381
68 [18]		46 [407] 420	130 [1151] 409	171 [1513] 400	215 [1903] 394	248 [2195] 387	291 [2575] 380	326 [2885] 374	361 [3195] 368	393 [3478] 358	428 [3788] 346					425	
76 [20]		38 [336] 469	120 [1062] 453	162 [1434] 448	199 [1760] 442	240 [2124] 435	278 [2460] 428	324 [2867] 421	357 [3159] 412	390 [3452] 401	425 [3761] 392					475	
Rotor Width		Overall Efficiency - 70 - 100% <input type="checkbox"/> 40 - 69% <input type="checkbox"/> 0 - 39% <input type="checkbox"/>															
Theoretical Torque - Nm [lb-in]		Theoretical Torque - Nm [lb-in]															
31.8 [1.252] mm [in]		43 [383]	89 [789]	176 [1556]	219 [1939]	265 [2345]	308 [2728]	352 [3111]	395 [3495]	441 [3901]	484 [4284]	527 [4667]					
		Displacement tested at 54°C [129°F] with an oil viscosity of 46cSt [213 SUS]															

► Performance data is typical. Performance of production units varies slightly from one motor to another. Operating at maximum continuous pressure and maximum continuous low simultaneously is not recommended. For additional information on product testing please refer to page 6.

DISPLACEMENT PERFORMANCE

		Pressure - bar [psi]								Max. Cont.	Max. Inter.			
200		17 [250]	35 [500]	69 [1000]	86 [1250]	104 [1500]	121 [1750]	138 [2000]	155 [2250]	172 [2500]	190 [2750]	207 [3000]		
198 cm ³ [12.1 in ³] / rev												Intermittent Ratings - 10% of Operation		
Torque - Nm [lb-in], Speed rpm												Theoretical rpm		
Flow - lpm [gpm]	2 [0.5]	38 [336] 10	87 [770] 8	172 [1522] 6	201 [1779] 5									10
	4 [1]	47 [416] 20	103 [912] 19	164 [1451] 14	201 [1779] 12	244 [2159] 9	295 [2611] 6	328 [2903] 3						20
	8 [2]	46 [407] 39	96 [850] 38	192 [1699] 36	241 [2133] 35	286 [2531] 34	330 [2920] 28	372 [3292] 25	417 [3690] 22	428 [3788] 17				40
	15 [4]	44 [389] 75	95 [841] 73	194 [1717] 70	241 [2133] 68	286 [2531] 65	333 [2947] 63	376 [3319] 59	419 [3708] 57	461 [4080] 52	498 [4407] 50	544 [4814] 40		76
	23 [6]	40 [354] 113	92 [814] 111	192 [1699] 109	240 [2124] 106	288 [2549] 103	333 [2947] 99	375 [3319] 96	421 [3726] 94	461 [4080] 89	505 [4469] 84	544 [4814] 78		116
	30 [8]	33 [292] 150	87 [770] 147	187 [1655] 142	236 [2088] 140	284 [2513] 135	330 [2920] 131	374 [3327] 126	421 [3726] 124	462 [4088] 117	504 [4460] 112	542 [4796] 106		152
	38 [10]	23 [204] 192	80 [708] 190	180 [1593] 185	230 [2035] 182	278 [2460] 177	325 [2876] 172	371 [3283] 167	415 [3673] 160	459 [4062] 154	498 [4407] 146	540 [4779] 140		192
	45 [12]	21 [186] 227	73 [646] 226	173 [1531] 219	223 [1973] 219	271 [2398] 212	318 [2814] 207	364 [3221] 201	409 [3619] 196	453 [4009] 186	491 [4345] 179	533 [4717] 174		227
	53 [14]	10 [88] 268	64 [566] 266	165 [1460] 260	214 [1894] 256	262 [2319] 251	309 [2735] 245	356 [3150] 240	400 [3540] 233	444 [3929] 227	483 [4274] 217	525 [4646] 210		268
	61 [16]		55 [487] 308	155 [1372] 300	204 [1805] 298	253 [2239] 291	300 [2655] 286	346 [3062] 279	391 [3460] 271	434 [3841] 264	472 [4177] 255	514 [4549] 248		308
	68 [18]		46 [407] 343	143 [1265] 332	191 [1690] 330	240 [2124] 322	287 [2540] 316	332 [2938] 310	377 [3336] 302	420 [3717] 296	457 [4044] 286	484 [4283] 276		343
	76 [20]		30 [265] 384	130 [1150] 374	179 [1584] 367	227 [2009] 363	275 [2434] 355	321 [2841] 349	365 [3230] 343	409 [3619] 333	430 [3805] 324	468 [4142] 314		384

Rotor Width

39.4 [1.553]
mm [in]

Overall Efficiency - 70 - 100% 40 - 69% 0 - 39%

Theoretical Torque - Nm [lb-in]

54 [481]	109 [963]	218 [1929]	272 [2407]	326 [2888]	381 [3369]	435 [3850]	489 [4332]	544 [4813]	598 [5294]	653 [5776]
----------	-----------	------------	------------	------------	------------	------------	------------	------------	------------	------------

Displacement tested at 54°C [129°F] with an oil viscosity of 46cSt [213 SUS]

		Pressure - bar [psi]								Max. Cont.	Max. Inter.			
240		17 [250]	35 [500]	69 [1000]	86 [1250]	104 [1500]	121 [1750]	138 [2000]	155 [2250]	172 [2500]	190 [2750]	207 [3000]		
236 cm ³ [14.4 in ³] / rev												Intermittent Ratings - 10% of Operation		
Torque - Nm [lb-in], Speed rpm												Theoretical rpm		
Flow - lpm [gpm]	2 [0.5]	47 [416] 7	98 [867] 6	197 [1743] 3	247 [2186] 3									8
	4 [1]	50 [443] 14	105 [929] 13	210 [1859] 11	260 [2301] 9	310 [2717] 7	354 [3133] 4	404 [3575] 4						16
	8 [2]	53 [469] 29	111 [982] 28	224 [1982] 26	277 [2451] 24	329 [2894] 21	377 [3336] 19	424 [3752] 16	469 [4151] 11	511 [4522] 8	582 [5151] 8			32
	15 [4]	52 [460] 60	114 [1000] 59	236 [2062] 56	290 [2575] 53	346 [3062] 50	399 [3531] 47	449 [3974] 44	496 [4390] 40	541 [4788] 36	598 [5292] 33	638 [5646] 28		63
	23 [6]	47 [416] 93	109 [956] 91	227 [2009] 88	285 [2522] 85	342 [3027] 81	397 [3513] 77	449 [3974] 71	500 [4425] 66	548 [4850] 60	595 [5266] 55	642 [5682] 52		95
	30 [8]	42 [372] 125	104 [903] 123	221 [1956] 119	280 [2469] 116	336 [2974] 111	391 [3460] 106	445 [3938] 100	497 [4398] 93	547 [4841] 87	592 [5248] 79	640 [5664] 73		126
	38 [10]	35 [310] 158	95 [832] 155	213 [1885] 150	272 [2398] 147	328 [2903] 142	384 [3398] 137	437 [3867] 131	489 [4328] 123	541 [4788] 115	587 [5195] 106	635 [5620] 99		158
	45 [12]	23 [204] 189	85 [752] 186	203 [1797] 182	262 [2319] 178	319 [2823] 174	375 [3319] 168	428 [3788] 160	480 [4248] 153	531 [4699] 145	575 [5089] 134	623 [5514] 125		189
	53 [14]		75 [655] 218	192 [1699] 214	250 [2213] 210	308 [2726] 205	365 [3310] 201	418 [3699] 191	470 [4160] 183	520 [4602] 174	564 [4991] 164	611 [5407] 154		220
	61 [16]		68 [593] 249	180 [1593] 245	238 [2106] 242	295 [2611] 236	350 [3106] 230	405 [3584] 222	458 [4053] 215	510 [4496] 205	551 [4876] 195	600 [5310] 184		252
	68 [18]		56 [487] 279	165 [1460] 273	221 [1956] 270	281 [2469] 267	335 [2965] 260	388 [3434] 251	440 [3894] 241	490 [4337] 231	545 [4797] 221	590 [5222] 208		283
	76 [20]		40 [354] 315	154 [1345] 307	210 [1841] 303	264 [2336] 295	320 [2832] 290	376 [3310] 282	428 [3770] 272	480 [4221] 261	530 [4691] 250	580 [5133] 238		315

Rotor Width

47.4 [1.865]
mm [in]

Overall Efficiency - 70 - 100% 40 - 69% 0 - 39%

Theoretical Torque - Nm [lb-in]

66 [584]	132 [1168]	265 [2345]	331 [2929]	397 [3513]	463 [4097]	529 [4681]	595 [5265]	661 [5850]	728 [6442]	794 [7027]
----------	------------	------------	------------	------------	------------	------------	------------	------------	------------	------------

Displacement tested at 54°C [129°F] with an oil viscosity of 46cSt [213 SUS]

► Performance data is typical. Performance of production units varies slightly from one motor to another. Operating at maximum continuous pressure and maximum continuous low simultaneously is not recommended. For additional information on product testing please refer to page 6.

DISPLACEMENT PERFORMANCE

		Pressure - bar [psi]						Max. Cont.		Max. Inter.		
320		17 [250]	35 [500]	52 [750]	69 [1000]	86 [1250]	104 [1500]	121 [1750]	138 [2000]	155 [2250]	172 [2500]	
322 cm ³ [19.6 in ³] / rev								Max. Cont.		Max. Inter.		
		Torque - Nm [lb-in], Speed rpm						Intermittent Ratings - 10% of Operation				
Flow - lpm [gpm]	2 [0.5]	60 [531]	134 [1186]	189 [1673]	238 [2106]							Theoretical rpm
	4 [1]	70 [619]	140 [1239]	239 [2115]	276 [2442]	324 [2867]	393 [3478]	403 [3566]				
	8 [2]	73 [646]	154 [1363]	233 [2062]	291 [2575]	333 [2947]	425 [3761]	487 [4310]	545 [4823]	621 [5496]	659 [5832]	
	15 [4]	79 [699]	152 [1345]	235 [2080]	311 [2752]	385 [3407]	452 [4000]	518 [4584]	555 [4912]	641 [5673]	690 [6106]	
	23 [6]	68 [602]	150 [1328]	227 [2009]	295 [2611]	378 [3345]	443 [3920]	512 [4531]	578 [5115]	621 [5496]	686 [6071]	
	30 [8]	56 [496]	145 [1283]	218 [1929]	286 [2531]	356 [3150]	436 [3858]	506 [4478]	560 [4956]	614 [5434]	665 [5885]	
	38 [10]	54 [478]	140 [1239]	202 [1788]	273 [2416]	348 [3080]	427 [3779]	501 [4434]	557 [4929]	604 [5345]	664 [5876]	
	45 [12]	38 [336]	134 [1186]	192 [1681]	260 [2301]	336 [2973]	409 [3619]	476 [4212]	542 [4796]	601 [5319]	642 [5681]	
	53 [14]	22 [195]	122 [1080]	173 [1531]	255 [2257]	323 [2858]	391 [3460]	451 [3991]	521 [4611]	582 [5150]	630 [5575]	
	61 [16]	11 [97]	105 [930]	157 [1389]	229 [2027]	298 [2637]	376 [3327]	440 [3894]	503 [4451]	557 [4929]	618 [5469]	
68 [18]		88 [779]	144 [1274]	220 [1947]	285 [2522]	356 [3150]	424 [3752]	487 [4310]	549 [4858]	602 [5327]		
76 [20]		70 [620]	126 [1062]	190 [1681]	262 [2319]	335 [2965]	410 [3628]	463 [4097]	528 [4673]	586 [5186]		
Max. Cont.		188	186	184	182	177	170	162	155	147	138	
Max. Inter.		235	233	233	230	226	218	209	202	193	185	
Rotor Width		Overall Efficiency - 70 - 100% <input type="checkbox"/> 40 - 69% <input type="checkbox"/> 0 - 39% <input type="checkbox"/>										
Theoretical Torque - Nm [lb-in]		87 [770] 177 [1566] 267 [2362] 354 [3132] 441 [3903] 533 [4717] 620 [5487] 708 [6265] 795 [7035] 887 [7850]										
63.5 [2.502] mm [in]		Displacement tested at 54°C [129°F] with an oil viscosity of 46cSt [213 SUS]										

		Pressure - bar [psi]						Max. Cont.		Max. Inter.		
400		17 [250]	35 [500]	52 [750]	69 [1000]	86 [1250]	104 [1500]	121 [1750]	138 [2000]			
400 cm ³ [24.4 in ³] / rev								Max. Cont.		Max. Inter.		
		Torque - Nm [lb-in], Speed rpm						Intermittent Ratings - 10% of Operation				
Flow - lpm [gpm]	2 [0.5]	82 [723]	165 [1459]	250 [2213]	329 [2912]	418 [3699]						Theoretical rpm
	4 [1]	86 [761]	175 [1549]	262 [2317]	345 [3053]	427 [3779]	497 [4398]	577 [5106]	660 [5841]			
	8 [2]	89 [791]	191 [1690]	284 [2513]	364 [3219]	448 [3962]	502 [4443]	606 [5363]	682 [6036]			
	15 [4]	87 [771]	189 [1673]	277 [2451]	378 [3346]	467 [4135]	529 [4679]	629 [5569]	698 [6177]			
	23 [6]	79 [703]	185 [1637]	271 [2398]	373 [3305]	464 [4110]	551 [4873]	631 [5584]	696 [6159]			
	30 [8]	70 [620]	176 [1558]	260 [2301]	364 [3217]	455 [4025]	550 [4868]	623 [5515]	676 [5982]			
	38 [10]	59 [523]	159 [1407]	239 [2115]	351 [3106]	442 [3913]	541 [4787]	611 [5410]	663 [5864]			
	45 [12]	52 [460]	145 [1283]	233 [2062]	335 [2968]	430 [3806]	529 [4684]	595 [5269]	645 [5705]			
	53 [14]	46 [404]	138 [1221]	215 [1903]	318 [2813]	409 [3622]	513 [4543]	578 [5115]	624 [5522]			
	61 [16]		113 [1000]	191 [1690]	298 [2641]	390 [3448]	496 [4393]	560 [4959]	606 [5364]			
68 [18]		96 [850]	178 [1575]	263 [2328]	365 [3230]	478 [4228]	517 [4572]	580 [5133]				
76 [20]		74 [655]	150 [1327]	240 [2122]	342 [3027]	436 [3855]	493 [4365]	560 [4956]				
Max. Cont.		152	147	145	139	130	127	121				
Max. Inter.		190	185	180	174	165	160	156				
Rotor Width		Overall Efficiency - 70 - 100% <input type="checkbox"/> 40 - 69% <input type="checkbox"/> 0 - 39% <input type="checkbox"/>										
Theoretical Torque - Nm [lb-in]		112 [992] 224 [1984] 336 [2976] 448 [3968] 560 [4960] 673 [5952] 785 [6944] 897 [7935]										
78.9 [3.106] mm [in]		Displacement tested at 54°C [129°F] with an oil viscosity of 46cSt [213 SUS]										

► Performance data is typical. Performance of production units varies slightly from one motor to another. Operating at maximum continuous pressure and maximum continuous low simultaneously is not recommended. For additional information on product testing please refer to page 6.

HOUSINGS

► Dimensions shown are without paint. Paint thickness can be up to 0.13 [.005].

2-HOLE, SAE A MOUNT, ALIGNED PORTS

A10 1/2-14 NPT **A11** 7/8-14 UNF **A18** G 1/2

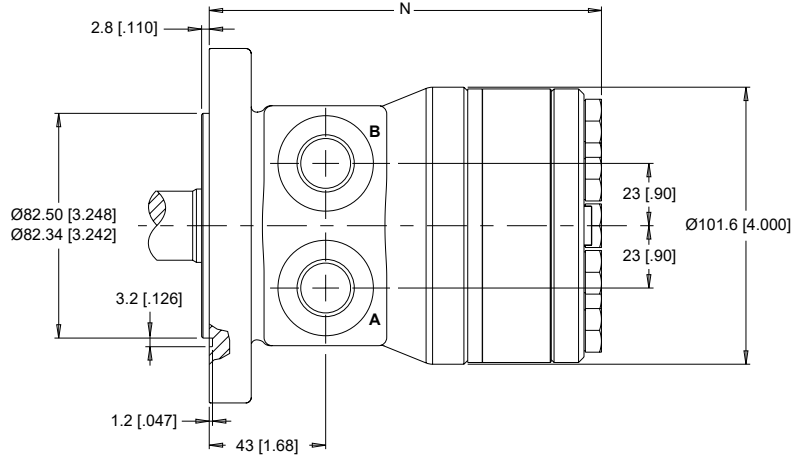
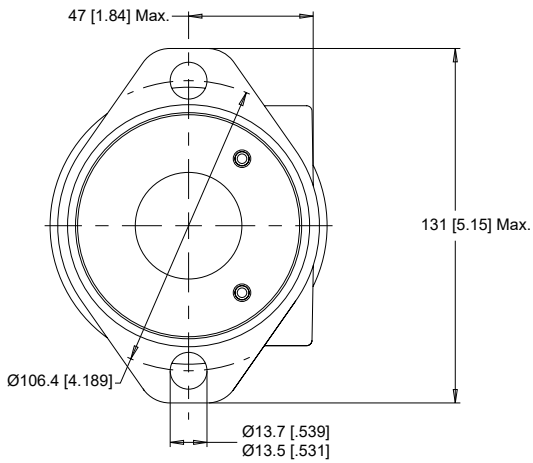

2-HOLE, SAE A MOUNT, ALIGNED MANIFOLD PORTS

A17 1/2" Drilled

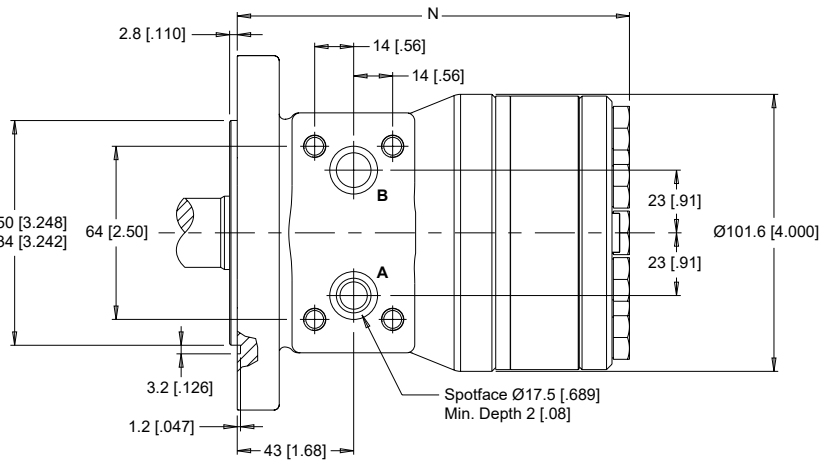
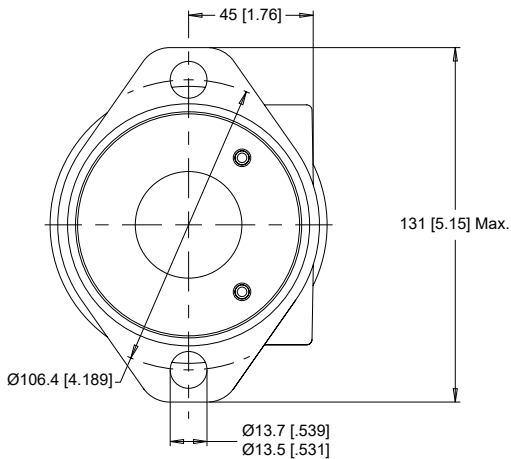

2-HOLE, SAE A MOUNT, SIDE PORTS

A71 7/8-14 UNF

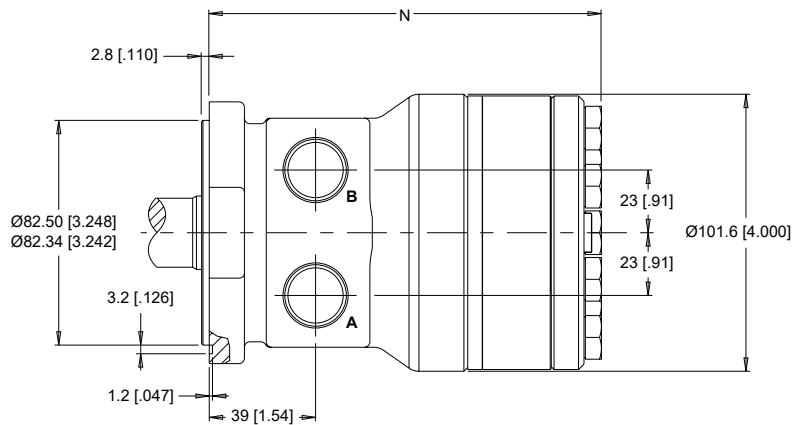
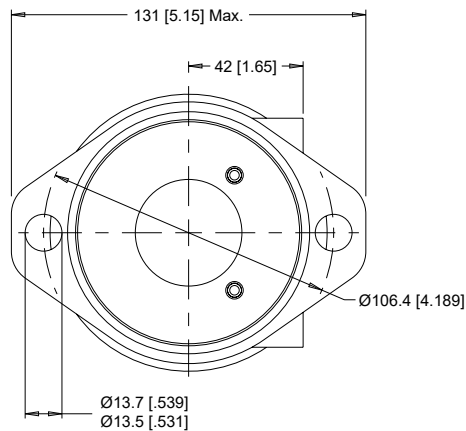

► Dimension N is charted on page 58.

HOUSINGS

► Dimensions shown are without paint. Paint thickness can be up to 0.13 [.005].

4-HOLE, SQUARE MOUNT, ALIGNED PORTS

F30 1/2-14 NPT **F31** 7/8-14 UNF

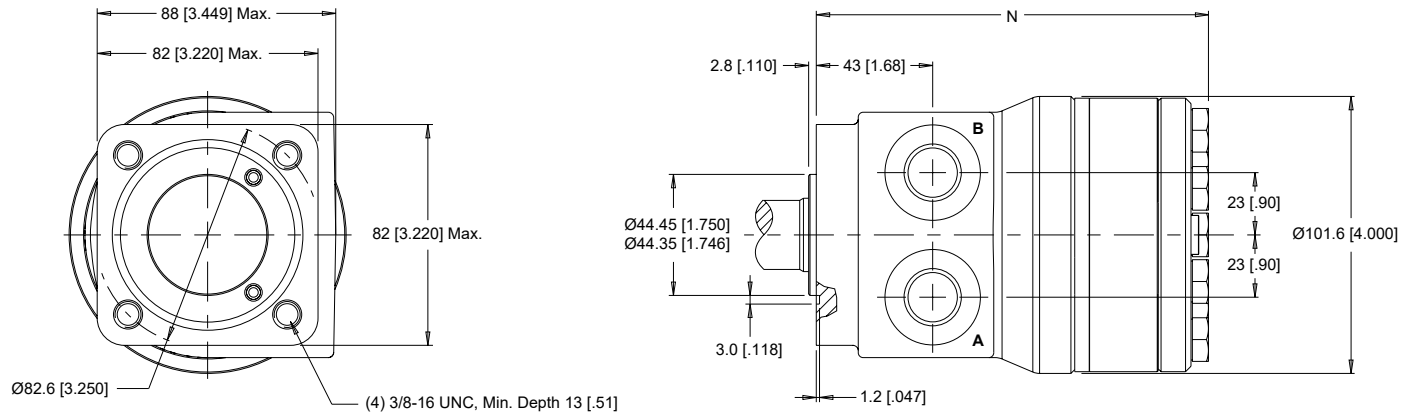

4-HOLE, SQUARE MOUNT, ALIGNED MANIFOLD PORTS

F37 1/2" Drilled

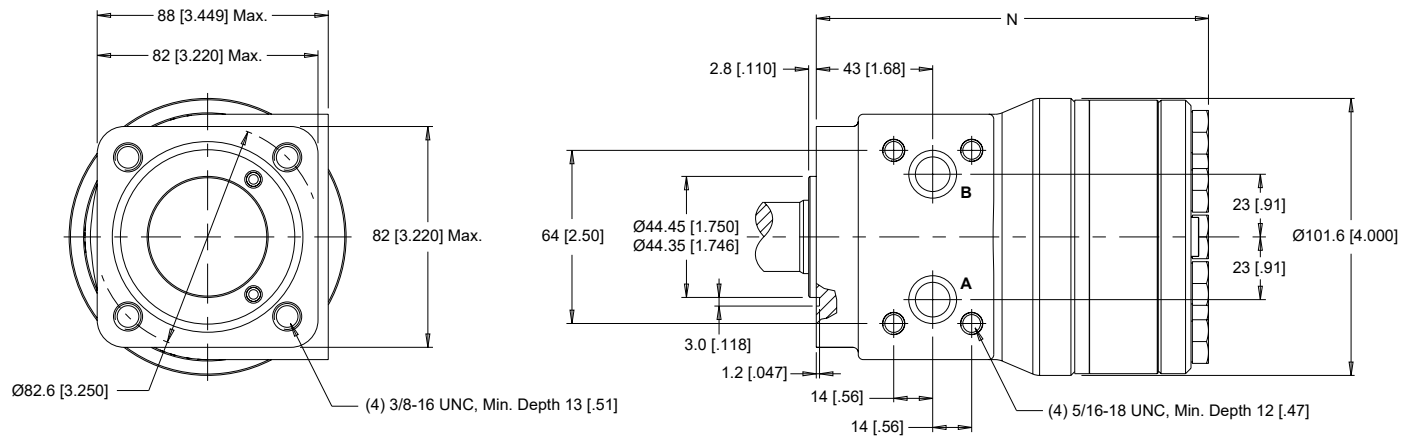

► Dimension N is charted on page 58.

TECHNICAL INFORMATION

ALLOWABLE SHAFT LOAD / BEARING CURVE

The bearing curve below represents the side load capacity of the motor at the centerline of the key for various motor speeds. Operating conditions within the shaded area will maintain acceptable oil film lubrication with recommended fluids. Operating conditions outside the shaded area are susceptible to motor failure due to oil starvation and/or excessive heat generation. Fluids with low lubricity or low viscosity may require the maximum load and speed ratings to be derated to provide acceptable motor life and performance.

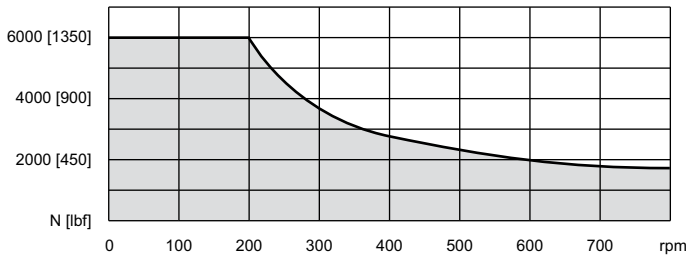

LENGTH & WEIGHT CHARTS

Dimension N is the overall motor length from the rear of the motor to the mounting flange surface and is referenced on detailed housing drawings listed on pages 56-57.

N	Length	Weight
#	mm [in]	kg [lb]
040	127 [4.98]	6.3 [14.0]
050	128 [5.06]	6.4 [14.2]
060	130 [5.13]	6.5 [14.3]
070	132 [5.21]	6.6 [14.5]
080	134 [5.28]	6.7 [14.8]
090	136 [5.34]	6.8 [14.9]
100	138 [5.44]	6.9 [15.1]
115	141 [5.54]	7.0 [15.3]
130	144 [5.67]	7.1 [15.6]
160	150 [5.92]	7.4 [16.2]
200	158 [6.22]	7.7 [17.0]
240	166 [6.53]	8.0 [17.7]
250	168 [6.60]	8.1 [17.9]
290	176 [6.92]	8.5 [18.7]
320	182 [7.17]	8.7 [19.2]
400	197 [7.77]	9.4 [20.7]

► 251 & 252 series motor weights can vary ± 0.5 kg [1 lb] depending on model configurations such as housing, shaft, endcover, options etc.

PERMISSIBLE SHAFT SEAL PRESSURE

The curve below represents allowable seal pressure at various speeds. Operation in the gray area results in maintaining the rated life of the shaft seal. Actual shaft seal pressure depends on motor configuration.

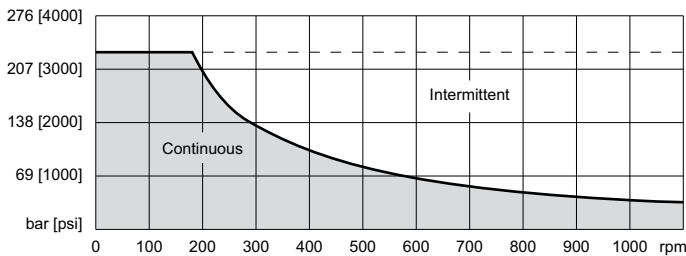

► With check valves and drain connection, the shaft seal pressure equals pressure in the drain line. With check valves and no drain connection, shaft seal pressure is identical to output pressure. No check valves and no drain connection, the shaft seal pressure is identical to the average value of input and output pressure.

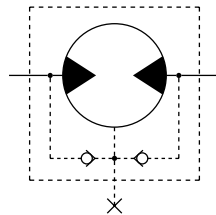

THRUST LOAD

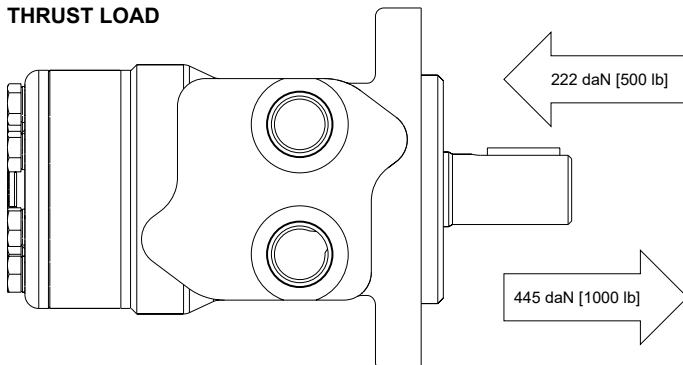

SHAFTS

10 1" Straight

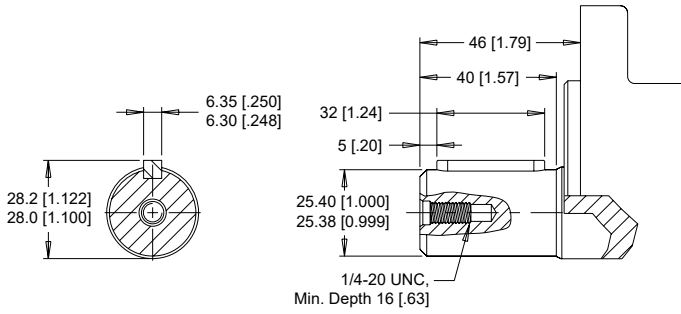

Max. Torque: 655 Nm [5800 lb-in]

12 25mm Straight

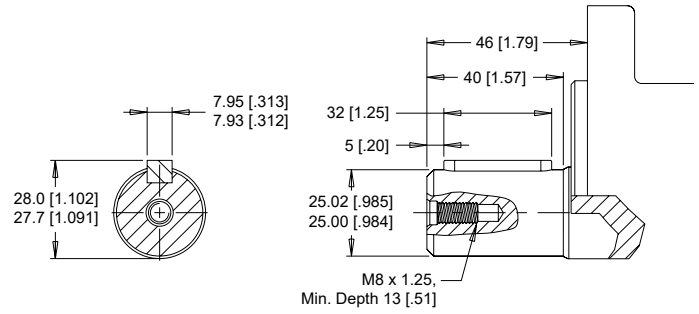

Max. Torque: 678 Nm [6000 lb-in]

02 1" 6B Spline, 1/4-20 Tap

04 1" 6B Spline, M8x1.25 Tap

03 1" 6B Spline, 5/16-18 Tap

6B Spline
SAE J499 Standard

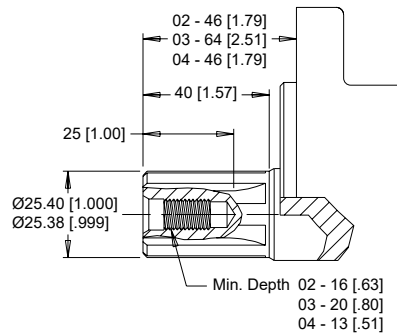
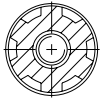

Max. Torque: 678 Nm [6000 lb-in]

ORDERING INFORMATION

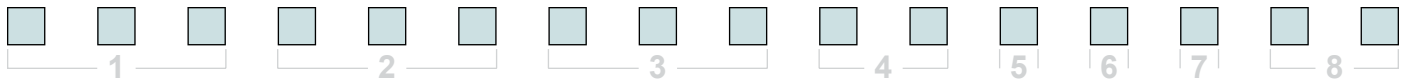

1. CHOOSE SERIES DESIGNATION

251 Standard Rotation **252** Reverse Rotation

▶ The 251 & 252 series are bi-directional.

2. SELECT A DISPLACEMENT OPTION

040	40 cm ³ /rev [2.5 in ³ /rev]	130	129 cm ³ /rev [7.9 in ³ /rev]
050	50 cm ³ /rev [3.1 in ³ /rev]	160	160 cm ³ /rev [9.8 in ³ /rev]
060	59 cm ³ /rev [3.6 in ³ /rev]	200	198 cm ³ /rev [12.1 in ³ /rev]
070	71 cm ³ /rev [4.3 in ³ /rev]	240	236 cm ³ /rev [14.4 in ³ /rev]
080	79 cm ³ /rev [4.9 in ³ /rev]	250	250 cm ³ /rev [15.3 in ³ /rev]
090	88 cm ³ /rev [5.4 in ³ /rev]	290	291 cm ³ /rev [17.8 in ³ /rev]
100	100 cm ³ /rev [6.1 in ³ /rev]	320	322 cm ³ /rev [19.6 in ³ /rev]
115	113 cm ³ /rev [6.9 in ³ /rev]	400	400 cm ³ /rev [24.4 in ³ /rev]

3. SELECT A MOUNT & PORT OPTION

A10	2-Hole, SAE A Mount, Aligned Ports, 1/2-14 NPT
A11	2-Hole, SAE A Mount, Aligned Ports, 7/8-14 UNF
A17	2-Hole, SAE A Mount, Aligned Manifold Ports, 1/2" Drilled
A18	2-Hole, SAE A Mount, Aligned Ports, G 1/2
A71	2-Hole, SAE A Mount, Aligned Side Ports, 7/8-14 UNF
F30	4-Hole, Square Mount, Aligned Ports, 1/2-14 NPT
F31	4-Hole, Square Mount, Aligned Ports, 7/8-14 UNF
F37	4-Hole, Square Mount, Aligned Manifold Ports, 1/2" Drilled

4. SELECT A SHAFT OPTION

02	6B Spline, 1/4 Tap	10	1" Straight
03	6B Spline, 5/16 Tap (Ext)	12	25mm Straight
04	6B Spline, M8 Tap		

▶ The 03 extended shaft is designed for use with one of the speed sensor options listed in STEP 7.

5. SELECT A PAINT OPTION

A	Black
B	Black, Unpainted Mounting Surface

6. SELECT A VALVE CAVITY / CARTRIDGE OPTION

A	None
----------	------

7. SELECT AN ADD-ON OPTION

A	Standard
W	Speed Sensor, Dual, 4-Pin Male Weatherpack Connector
X	Speed Sensor, Dual, 4-Pin M12 Male Connector
Y	Speed Sensor, Single, 3-Pin Male Weatherpack Connector
Z	Speed Sensor, Single, 4-Pin M12 Male Connector

8. SELECT A MISCELLANEOUS OPTION

AA	None
AC	Freeturning Rotor

HOUSINGS

► Dimensions shown are without paint. Paint thickness can be up to 0.13 [0.005].

2-HOLE, SAE A MOUNT, ALIGNED PORTS

A10 1/2-14 NPT **A11** 7/8-14 UNF

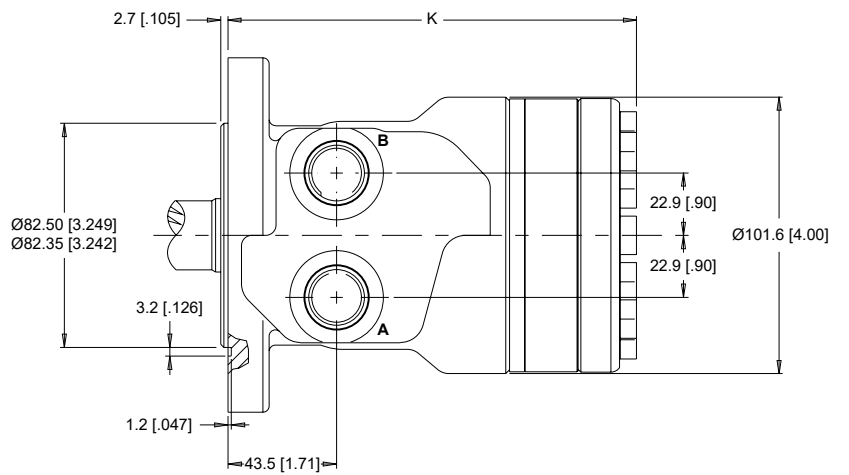
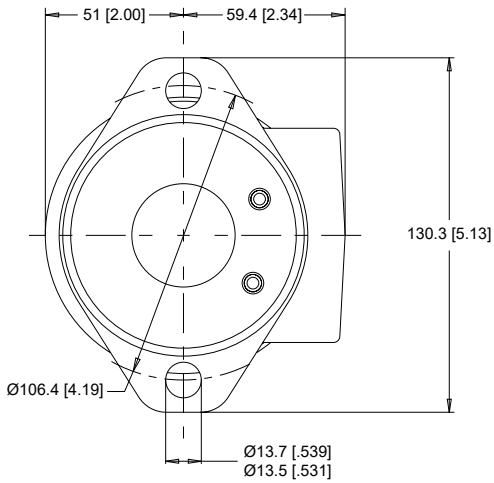

2-HOLE, SAE A MOUNT, OFFSET PORTS

A12 G 1/2 **A62** G 1/2 (TP)

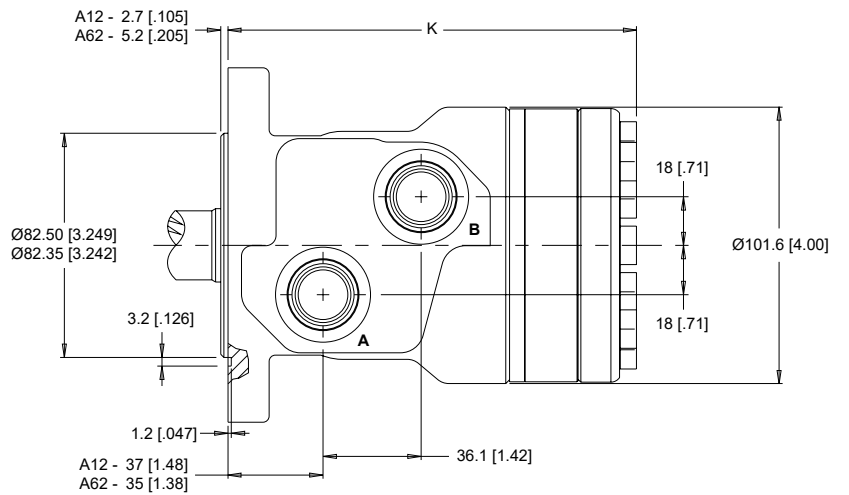
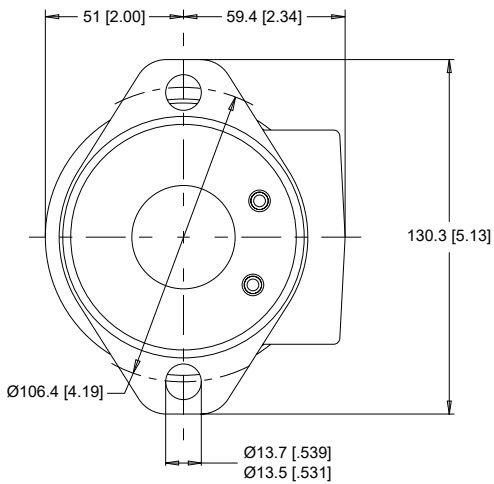

2-HOLE, SAE A MOUNT, OFFSET MANIFOLD PORTS

A13 G 1/2 **A1D** 7/8-14 UNF **A63** G 1/2 (TP)

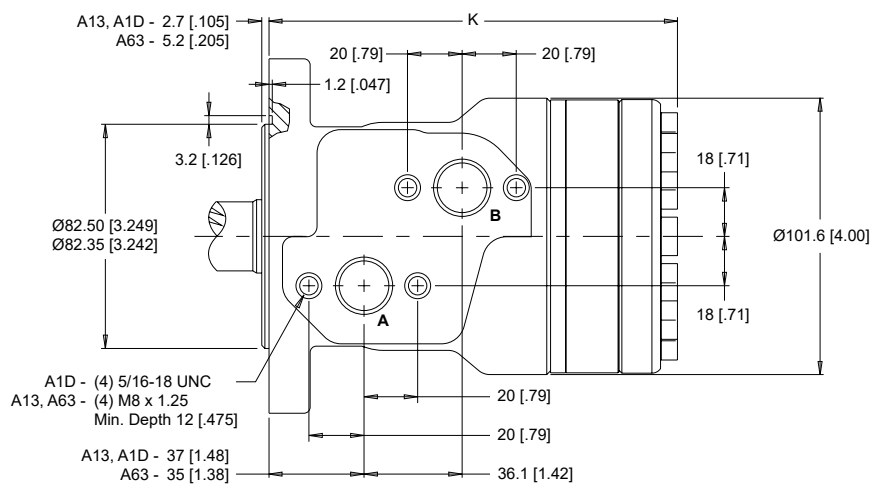
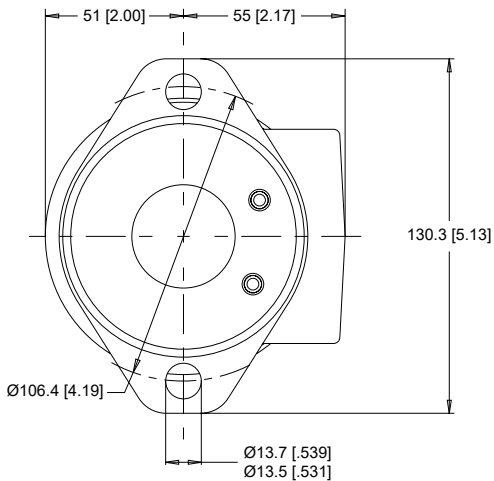

► Dimension K is charted on page 65. ► (TP) - Taller Pilot Height. Refer to detailed drawing for dimensional differences.

HOUSINGS

► Dimensions shown are without paint. Paint thickness can be up to 0.13 [.005].

2-HOLE, SAE A MOUNT, ALIGNED MANIFOLD PORTS

A17 1/2" Drilled

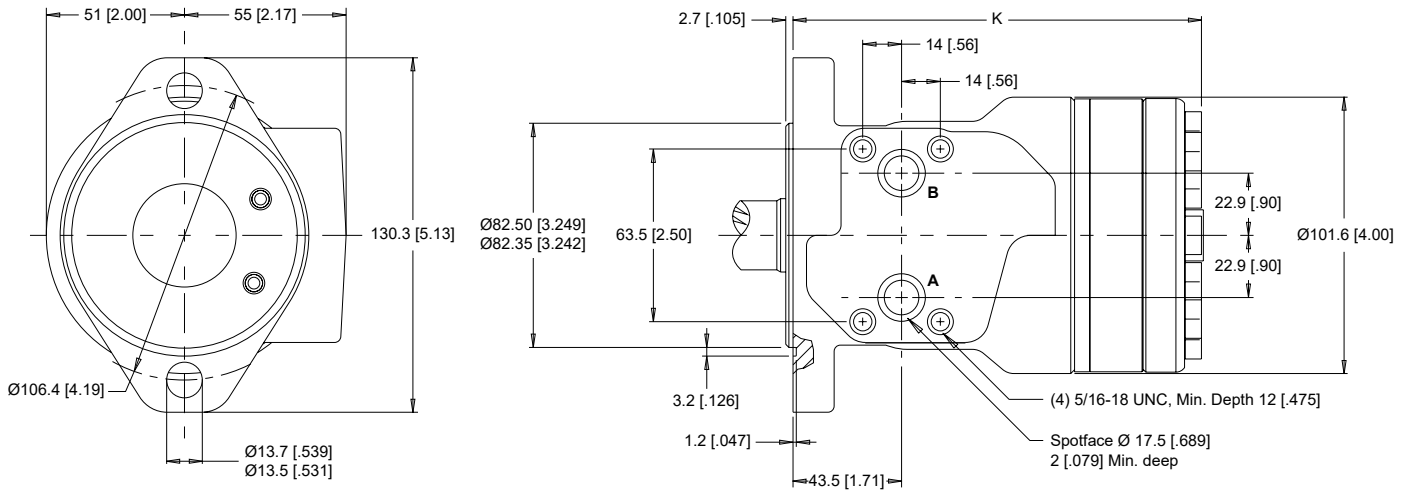

2-HOLE, SAE A MOUNT, OFFSET PORTS, VALVE CAVITY

A19 7/8-14 UNF

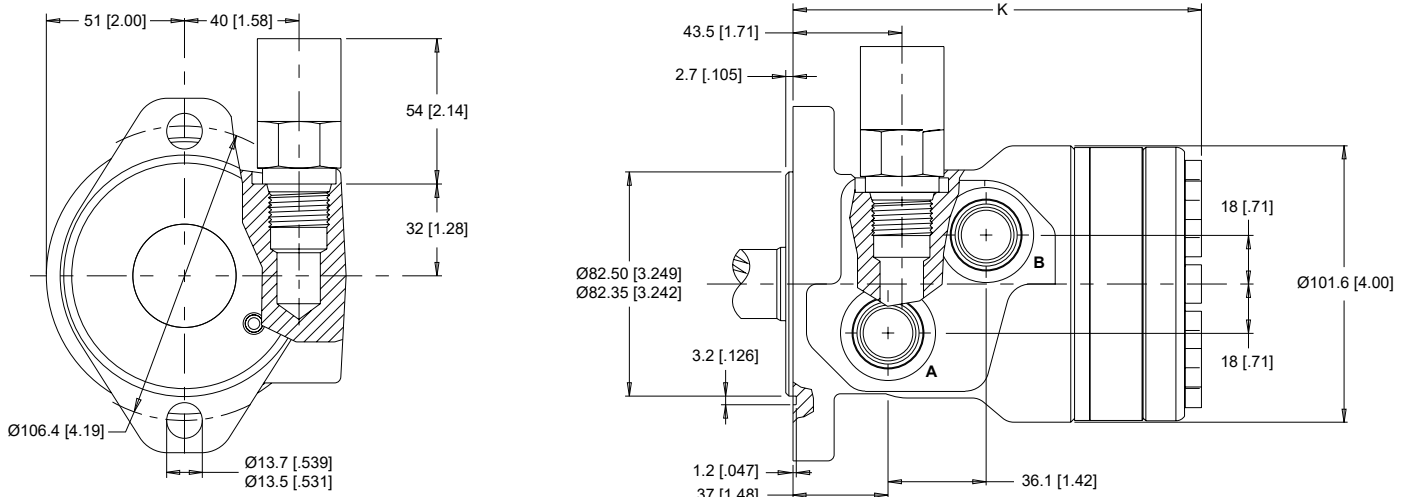

4-HOLE, MAGNETO MOUNT, ALIGNED PORTS

A30 1/2-14 NPT

A31 7/8-14 UNF

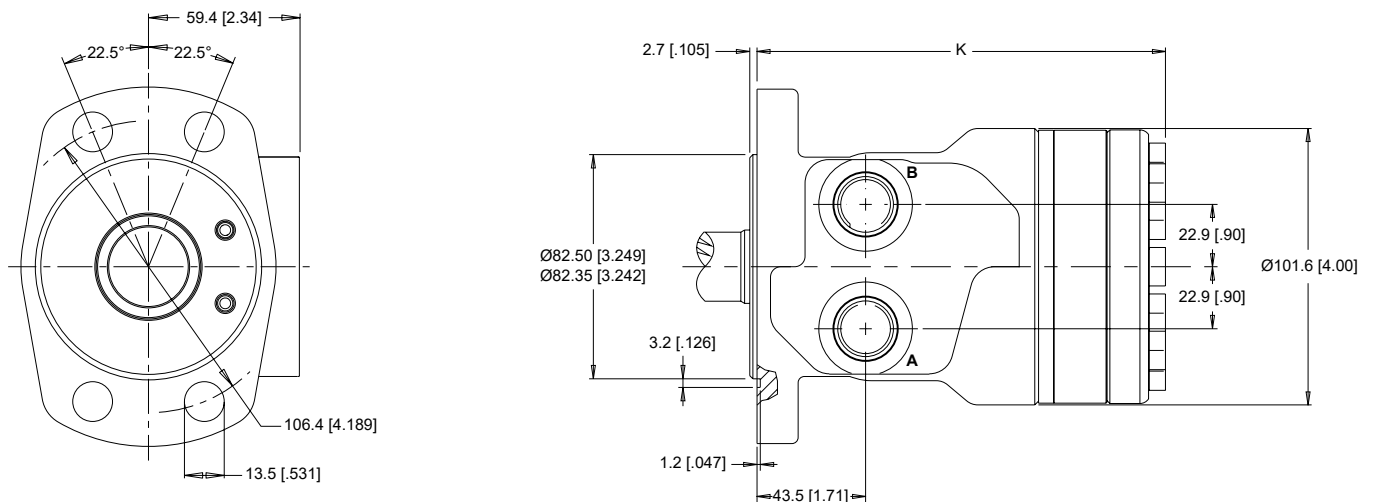

► Dimension K is charted on page 65.

HOUSINGS

► Dimensions shown are without paint. Paint thickness can be up to 0.13 [.005].

4-HOLE, MAGNETO MOUNT, OFFSET MANIFOLD PORTS

A33 G 1/2

A3D 7/8-14 UNF

AC3 G 1/2 (TP)

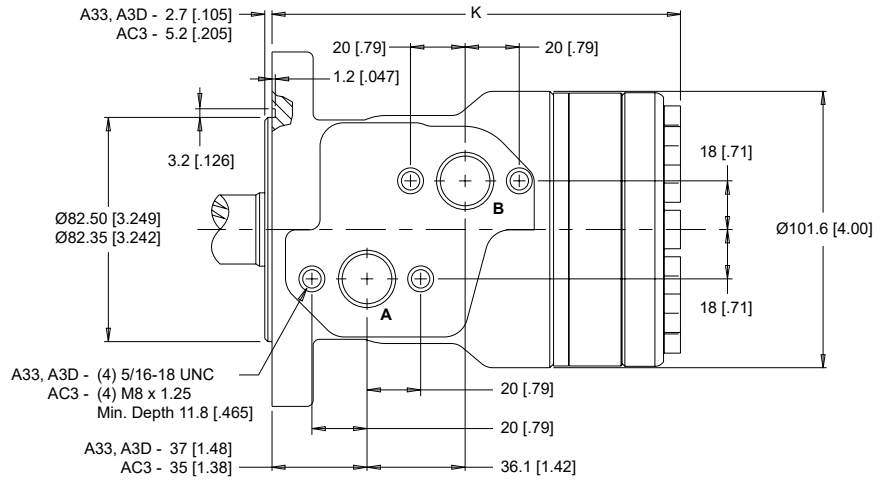
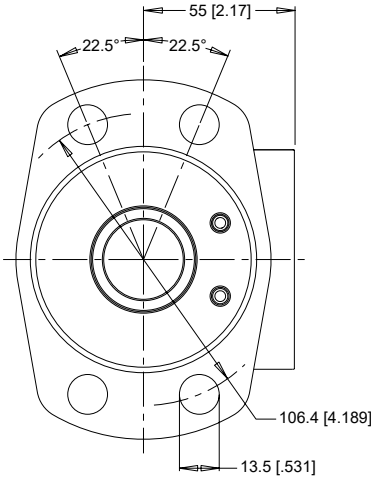

2-HOLE, SAE B MOUNT, ALIGNED PORTS

B11 7/8-14 UNF

B18 G 1/2

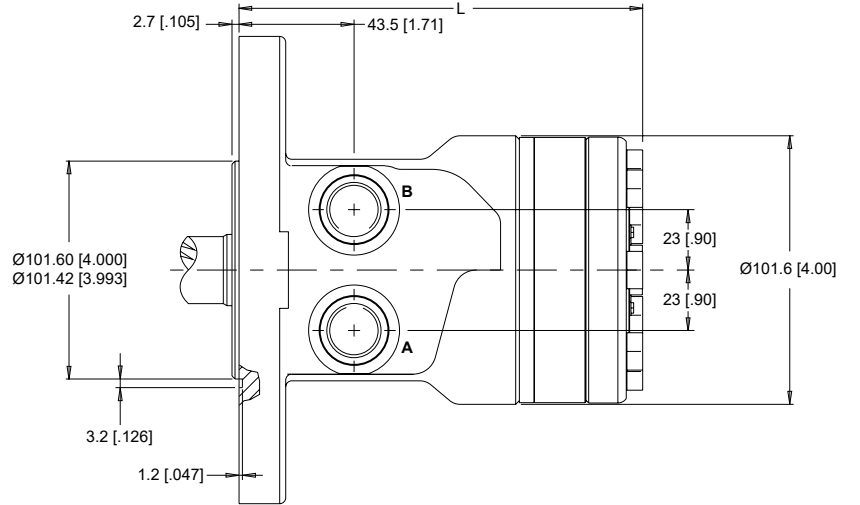
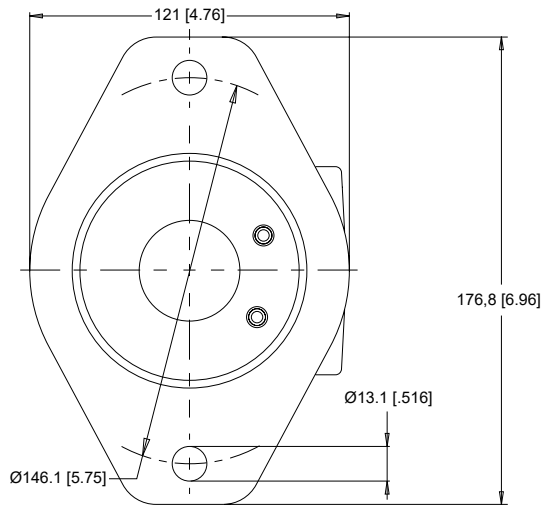

4-HOLE, SQUARE MOUNT, ALIGNED PORTS

F30 1/2-14 NPT

F31 7/8-14 UNF

F38 G 1/2

G38 G 1/2

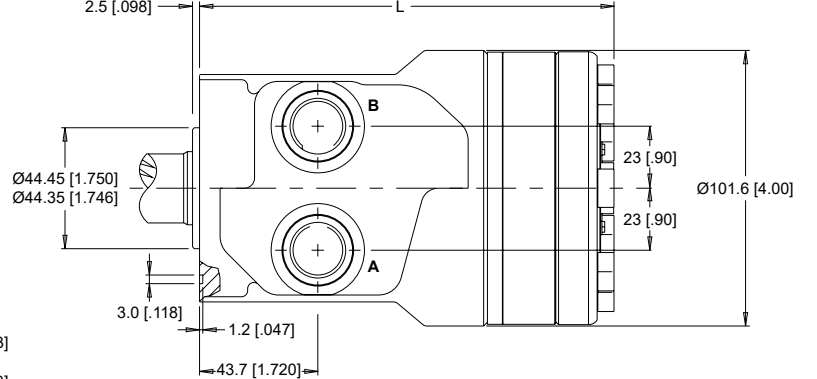
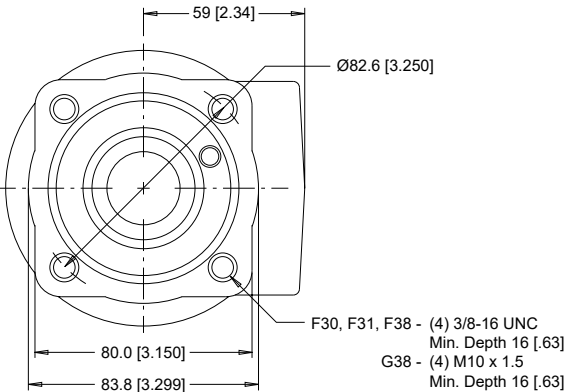

► Dimensions K & L are charted on page 65. ► (TP) - Taller Pilot Height. Refer to detailed drawing for dimensional differences.

HOUSINGS

► Dimensions shown are without paint. Paint thickness can be up to 0.13 [.005].

4-HOLE, SQUARE MOUNT, ALIGNED MANIFOLD PORTS **F37** 1/2" Drilled **G37** 1/2" Drilled

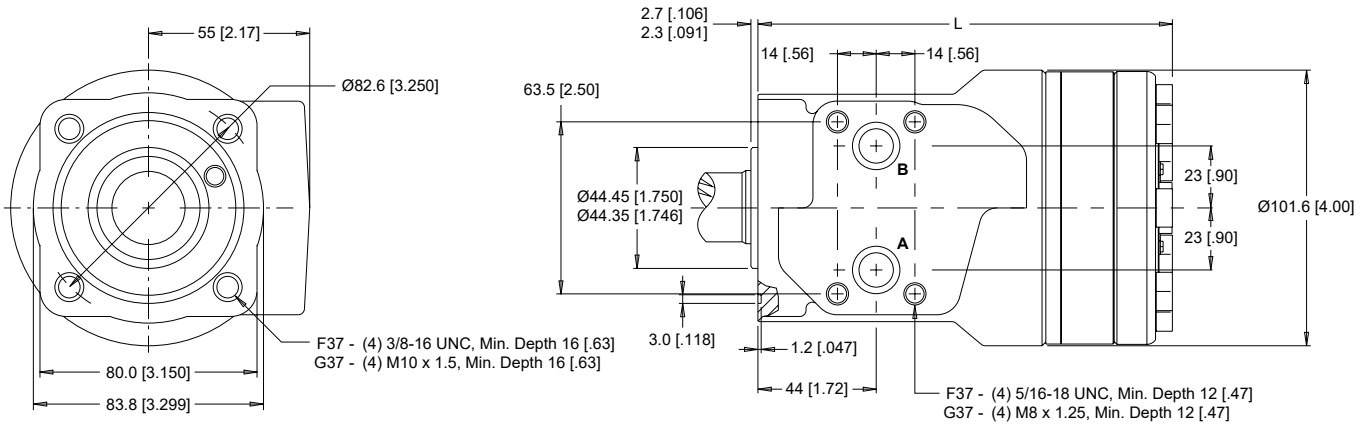

4-HOLE, SQUARE MOUNT, OFFSET MANIFOLD PORTS **F33** G 1/2 **F3D** 7/8-14 UNF

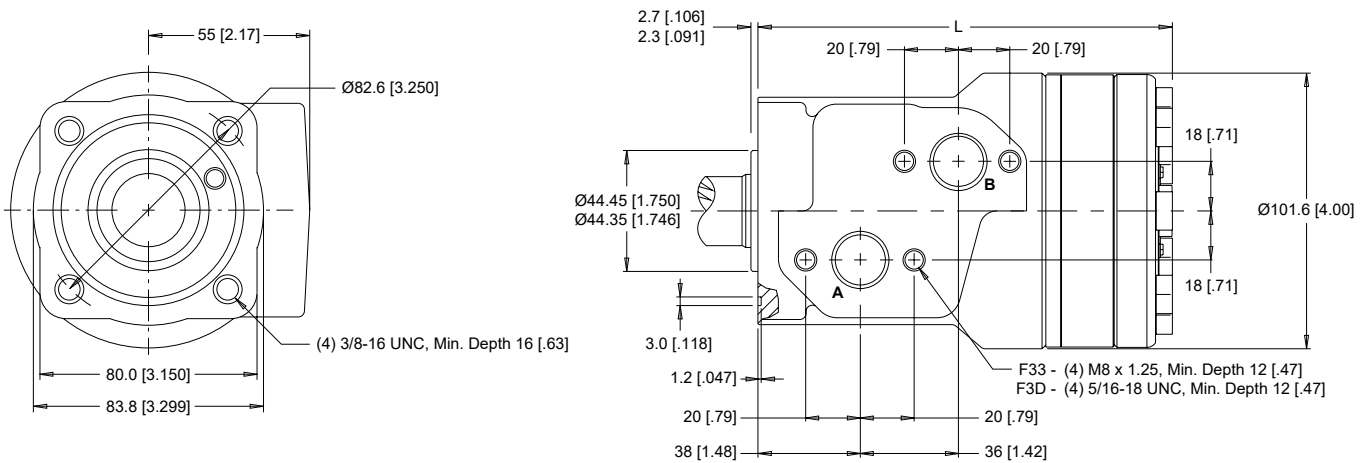

4-HOLE, SQUARE MOUNT, OFFSET PORTS, VALVE CAVITY **F39** 7/8-14 UNF

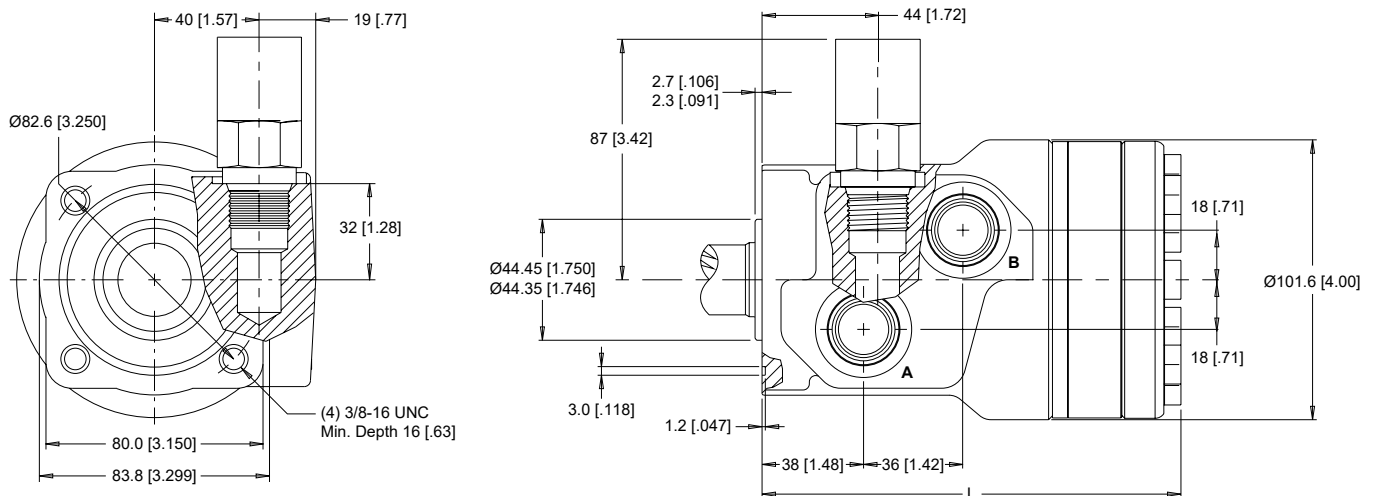

► Dimension L is charted on page 65.

TECHNICAL INFORMATION

ALLOWABLE SHAFT LOAD / BEARING CURVE

The bearing curve below represents the side load capacity of the motor at the centerline of the key for various motor speeds. Operating conditions within the shaded area will maintain acceptable oil film lubrication with recommended fluids. Operating conditions outside the shaded area are susceptible to motor failure due to oil starvation and/or excessive heat generation. Fluids with low lubricity or low viscosity may require the maximum load and speed ratings to be derated to provide acceptable motor life and performance.

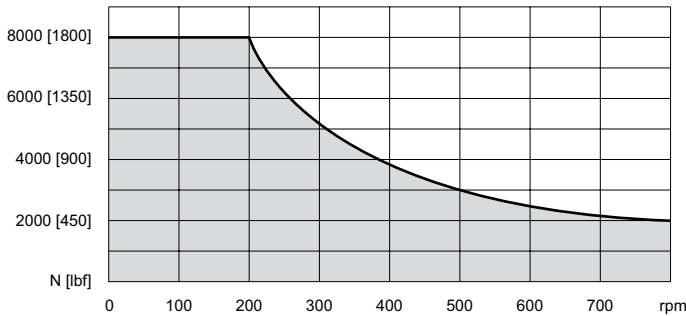

PERMISSIBLE SHAFT SEAL PRESSURE

The curve below represents allowable seal pressure at various speeds. Operation in the gray area results in maintaining the rated life of the shaft seal. Actual shaft seal pressure depends on motor configuration.

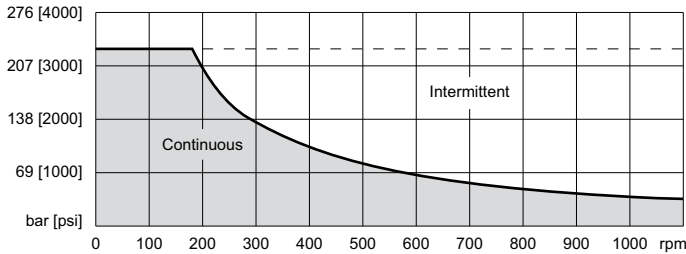

- ▶ With check valves and drain connection, the shaft seal pressure equals pressure in the drain line. With check valves and no drain connection, shaft seal pressure is identical to output pressure. No check valves and no drain connection, the shaft seal pressure is identical to the average value of input and output pressure.

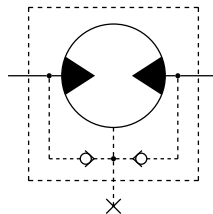

THRUST LOAD

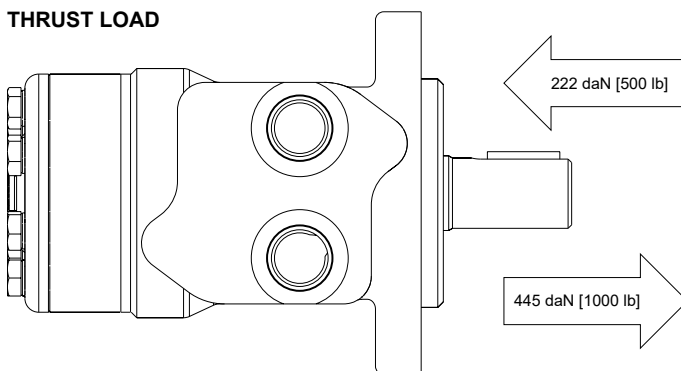

LENGTH & WEIGHT CHARTS

Dimension K is the overall motor length from the rear of the motor to the mounting flange surface and is referenced on detailed housing drawings listed on pages 61-63.

K	3mm Pilot	8mm Pilot	Weight
#	mm [in]	mm [in]	kg [lb]
040	142 [5.60]	140 [5.50]	6.6 [14.5]
050	144 [5.67]	142 [5.57]	6.6 [14.5]
060	146 [5.74]	144 [5.64]	6.7 [14.7]
070	147 [5.80]	145 [5.70]	6.7 [14.7]
080	150 [5.91]	148 [5.81]	6.8 [15.0]
090	151 [5.96]	149 [5.86]	6.8 [15.0]
100	154 [6.06]	152 [5.96]	6.9 [15.2]
115	156 [6.15]	154 [6.05]	7.1 [15.6]
130	160 [6.28]	158 [6.18]	7.3 [16.0]
160	166 [6.53]	164 [6.43]	7.5 [16.5]
200	173 [6.83]	171 [6.73]	8.0 [17.6]
240	182 [7.15]	180 [7.05]	8.5 [18.7]
250	183 [7.20]	181 [7.10]	8.5 [18.7]
290	192 [7.56]	190 [7.46]	8.8 [19.4]
320	198 [7.78]	196 [7.68]	9.0 [19.8]
400	213 [8.39]	211 [8.29]	9.8 [21.6]

Dimension L is the overall motor length from the rear of the motor to the mounting flange surface and is referenced on detailed housing drawings listed on pages 63-64.

L	Square & B Mounts	B Mount Weight	Sq. Mount Weight
#	mm [in]	kg [lb]	kg [lb]
040	142 [5.60]	7.8 [17.2]	5.3 [11.8]
050	144 [5.67]	7.8 [17.2]	5.3 [11.9]
060	146 [5.74]	7.9 [17.4]	5.4 [11.9]
070	147 [5.80]	7.9 [17.4]	5.4 [11.9]
080	150 [5.91]	8.0 [17.6]	5.5 [12.1]
090	151 [5.96]	8.0 [17.6]	5.5 [12.1]
100	154 [6.06]	8.1 [17.8]	5.6 [12.3]
115	156 [6.15]	8.3 [18.3]	5.8 [12.8]
130	160 [6.28]	8.5 [18.7]	6.0 [13.2]
160	166 [6.53]	8.7 [19.1]	6.2 [13.7]
200	173 [6.83]	9.2 [20.2]	6.7 [14.8]
240	182 [7.15]	9.7 [21.3]	7.2 [15.9]
250	183 [7.20]	9.7 [21.3]	7.2 [15.9]
290	192 [7.56]	10.0 [22.0]	7.5 [16.5]
320	198 [7.78]	10.2 [22.4]	7.7 [17.0]
400	213 [8.39]	11.0 [24.2]	8.5 [18.7]

- ▶ 255 & 256 series motor weights can vary ± 0.5 kg [1 lb] depending on model configurations such as housing, shaft, endcover, options etc.

SHAFTS

01 7/8" 13 Tooth Spline

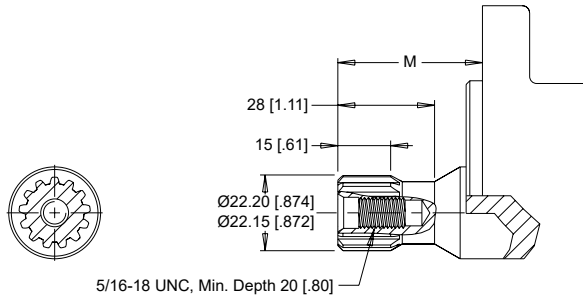

Max. Torque: 170 Nm [1500 lb-in]

02 1" 6B Spline, 5/16-18 Tap

6B Spline
SAE J499 Standard

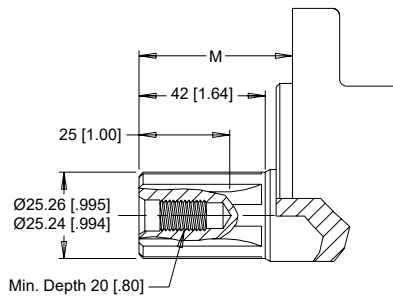
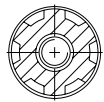

Max. Torque: 678 Nm [6000 lb-in]

04 1" 6B Spline, M8x1.25 Tap

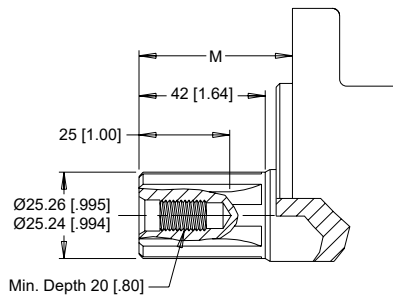

05 1" - 9.5 [.375] Pinhole

53 1" - 10.3 [.406] Pinhole

66 1" - 8.0 [.315] Pinhole

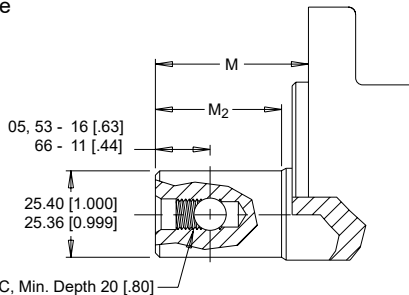
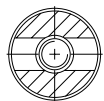

Max. Torque: 678 Nm [6000 lb-in]

10 1" Straight, 5/16-18 Tap

11 1" Straight, M8x1.25 Tap

15 1" Straight Ext., 5/16-18 Tap

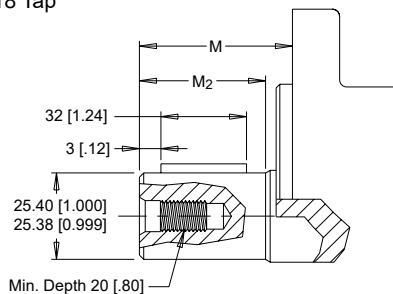
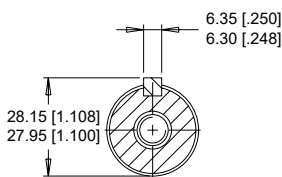

Max. Torque: 655 Nm [5800 lb-in]

12 25mm Straight

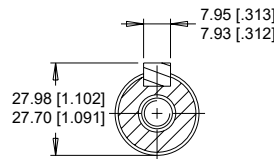

16 25mm Straight Extended

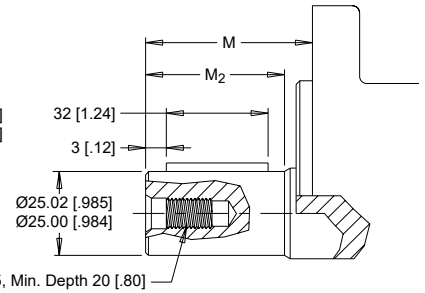

Max. Torque: 678 Nm [6000 lb-in]

13 1" Tapered

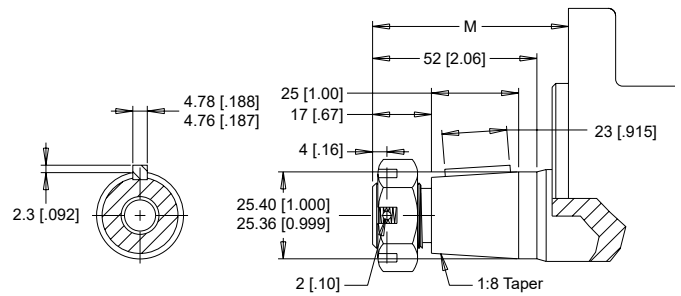

Max. Torque: 655 Nm [5800 lb-in]

MOUNTING / SHAFT LENGTH CHART

Dimension M is the overall distance from the motor mounting surface to the end of the shaft.

Additional shaft length information, if necessary, is noted as M₂ and does not increase or decrease the listed M dimensions in this chart. The overall shaft lengths are already factored into the overall distance from the mounting surface to the end of the shaft.

M	3mm Pilot	5mm Pilot	M ₂
#	mm [in]	mm [in]	mm [in]
01	40 [1.59]	43 [1.69]	N/A
02	48 [1.88]	51 [1.98]	N/A
04	48 [1.88]	51 [1.98]	N/A
05	48 [1.88]	51 [1.98]	42 [1.64]
10	48 [1.88]	51 [1.98]	42 [1.64]
12	53 [2.08]	56 [2.18]	43 [1.69]
13	58 [2.29]	61 [2.39]	N/A
15	64 [2.52]	67 [2.62]	58 [2.28]
16	64 [2.52]	67 [2.62]	59 [2.34]
53	48 [1.88]	51 [1.98]	42 [1.64]
66	54 [2.13]	57 [2.23]	48 [1.89]

ORDERING INFORMATION

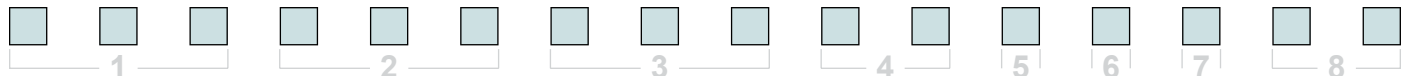

1. CHOOSE SERIES DESIGNATION

- 255** Standard Rotation
- 256** Reverse Rotation

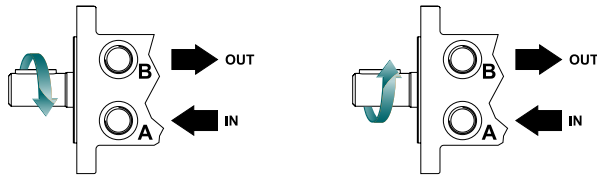

► The 255 & 256 series are bi-directional.

2. SELECT A DISPLACEMENT OPTION

040	40 cm ³ /rev [2.5 in ³ /rev]	130	129 cm ³ /rev [7.9 in ³ /rev]
050	50 cm ³ /rev [3.1 in ³ /rev]	160	160 cm ³ /rev [9.8 in ³ /rev]
060	59 cm ³ /rev [3.6 in ³ /rev]	200	198 cm ³ /rev [12.1 in ³ /rev]
070	71 cm ³ /rev [4.3 in ³ /rev]	240	236 cm ³ /rev [14.4 in ³ /rev]
080	79 cm ³ /rev [4.9 in ³ /rev]	250	250 cm ³ /rev [15.3 in ³ /rev]
090	88 cm ³ /rev [5.4 in ³ /rev]	290	291 cm ³ /rev [17.8 in ³ /rev]
100	100 cm ³ /rev [6.1 in ³ /rev]	320	322 cm ³ /rev [19.6 in ³ /rev]
115	113 cm ³ /rev [6.9 in ³ /rev]	400	400 cm ³ /rev [24.4 in ³ /rev]

3. SELECT A MOUNT & PORT OPTION

A10	2-Hole, SAE A Mount, Aligned Ports, 1/2-14 NPT
A11	2-Hole, SAE A Mount, Aligned Ports, 7/8-14 UNF
A12	2-Hole, SAE A Mount, Offset Ports, G 1/2
A13	2-Hole, SAE A Mount, Offset Manifold Ports, G 1/2
A1D	2-Hole, SAE A Mount, Offset Manifold Ports, 7/8-14 UNF
A19	2-Hole, SAE A Mount, Offset Ports, Valve Cavity 7/8-14 UNF
A30	4-Hole, Magneto Mount, Aligned Ports, 1/2-14 NPT
A31	4-Hole, Magneto Mount, Aligned Ports, 7/8-14 UNF
A33	4-Hole, Magneto Mount, Offset Manifold Ports, G 1/2
A3D	4-Hole, Magneto Mount, Offset Manifold Ports, 7/8-14 UNF
A62	2-Hole, SAE A Mount, Offset Ports, G 1/2 (TP)
A63	2-Hole, SAE A Mount, Offset Manifold Ports, G 1/2 (TP)
AC3	4-Hole, Magneto Mount, Offset Manifold Ports, G 1/2 (TP)
B11	2-Hole, SAE B Mount, Aligned Ports, 7/8-14 UNF
B18	2-Hole, SAE B Mount, Aligned Ports, G 1/2
F30	4-Hole, Square Mount, Aligned Ports, 1/2-14 NPT
F31	4-Hole, Square Mount, Aligned Ports, 7/8-14 UNF
F33	4-Hole, Square Mount, Offset Manifold Ports, G 1/2
F37	4-Hole, 3/8-16 UNC, Mount, Aligned Manifold Ports, 1/2" Drilled

► (TP) - Tall pilot. Speed sensor option is not available on tall pilot housings.

3. SELECT A MOUNT & PORT OPTION

- F38** 4-Hole, Square Mount, Aligned Ports, G 1/2
- F39** 4-Hole, Square Mount, Offset Ports, Valve Cavity 7/8-14 UNF
- F3D** 4-Hole, Square Mount, Offset Manifold Ports, 7/8-14 UNF
- G37** 4-Hole, M10x1.5, Square Mount, Aligned Manifold Ports, 1/2" Drilled
- G38** 4-Hole, Square Mount, Aligned Ports, G 1/2

4. SELECT A SHAFT OPTION

01	7/8" 13 Tooth Spline	12	25mm Straight
02	1" 6B Spline, 5/16-18 Tap	13	1" Tapered
04	1" 6B Spline, M8x1.25 Tap	15	1" Straight Extended
05	1" - 9.5 [.375] Pinhole	16	25mm Straight Extended
10	1" Straight 5/16-18 Tap	53	1" - 10.3 [.406] Pinhole
11	1" Straight M8x1.25 Tap	66	1" - 8.0 [.315] Pinhole

► The 15 & 16 extended shafts are designed for use with one of the speed sensor options listed in STEP 7.

5. SELECT A PAINT OPTION

- A** Black
- B** Black, Unpainted Mounting Surface

6. SELECT A VALVE CAVITY / CARTRIDGE OPTION

A	None	F	121 bar [1750 psi] Relief
B	Valve Cavity Only	G	138 bar [2000 psi] Relief
C	69 bar [1000 psi] Relief	J	173 bar [2500 psi] Relief
D	86 bar [1250 psi] Relief	L	207 bar [3000 psi] Relief
E	104 bar [1500 psi] Relief		

► Valve cavity is only available on the A19 & F39 housings.

7. SELECT AN ADD-ON OPTION

- A** Standard
- B** Lock Nut
- C** Solid Hex Nut
- W** Speed Sensor, Dual, 4-Pin Male Weatherpack Connector
- X** Speed Sensor, Dual, 4-Pin M12 Male Connector
- Y** Speed Sensor, Single, 3-Pin Male Weatherpack Connector
- Z** Speed Sensor, Single, 4-Pin M12 Male Connector

8. SELECT A MISCELLANEOUS OPTION

- AA** None
- EG** Viton Shaft Seal