

OVERVIEW

The WP motor series is an economical alternative to more complex roller gerotor designs and still provides high efficiency across a wide performance range. These motors are intended for light-duty applications requiring high torque in a compact package and are suitable for industrial and mobile applications including car wash brushes, food processing equipment, conveyors, machine tools, agricultural equipment, sweepers, skid steer attachments, and more.

FEATURES / BENEFITS

- Built-in check valves offer versatility and increased seal life.
- A variety of mounts and shafts provide flexibility in application design.
- Spool valve design gives superior performance and smooth operation over a wide speed and torque range.
- Standard high pressure shaft seals offer superior seal life and performance.

TYPICAL APPLICATIONS

agriculture equipment, conveyors, carwashes, sweepers, food processing, grain augers, spreaders, feed rollers, augers, brush drives and more

SERIES DESCRIPTIONS

155/156 - Hydraulic Motor
Standard

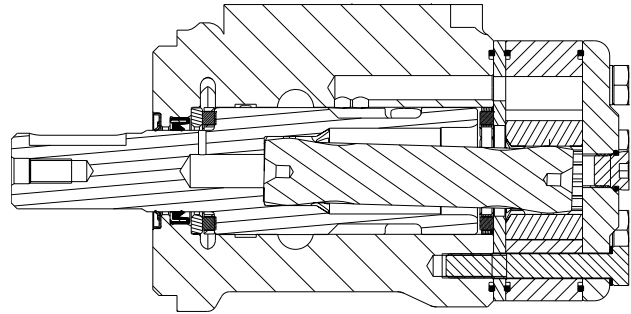

157/158 - Hydraulic Motor
With Needle Bearings

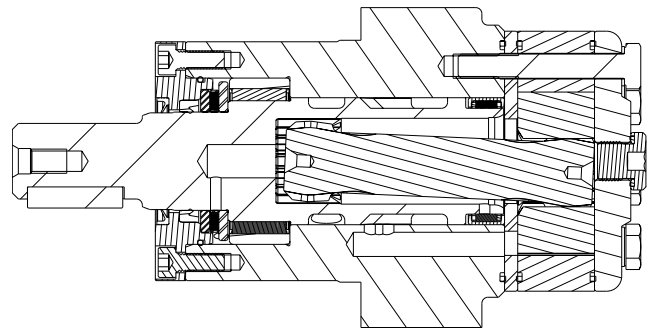

SPECIFICATIONS

CODE	Displacement cm ³ [in ³ /rev]	Max. Speed rpm		Max. Flow lpm [gpm]		Max. Torque Nm [lb-in]		Max. Pressure bar [psi]		
		cont.	inter.	cont.	inter.	cont.	inter.	cont.	inter.	peak
025	25 [1.5]	1570	1687	40 [11]	45 [12]	35 [310]	48 [425]	100 [1450]	140 [2030]	225 [3260]
032	32 [2.0]	1550	1674	50 [13]	55 [15]	45 [398]	57 [504]	100 [1450]	140 [2030]	225 [3260]
040	40 [2.5]	1471	1670	60 [16]	70 [19]	65 [575]	74 [655]	100 [1450]	140 [2030]	225 [3260]
050	50 [3.0]	1208	1500	60 [16]	75 [20]	91 [805]	108 [956]	140 [2030]	175 [2540]	240 [3480]
060	59 [3.6]	1185	1271	60 [16]	75 [20]	125 [1106]	136 [1204]	160 [2320]	175 [2540]	240 [3480]
080	78 [4.8]	896	960	60 [16]	75 [20]	164 [1451]	183 [1620]	160 [2320]	175 [2540]	240 [3480]
100	96 [5.9]	728	780	60 [16]	75 [20]	195 [1726]	213 [1885]	160 [2320]	175 [2540]	240 [3480]
125	125 [7.6]	559	599	60 [16]	75 [20]	258 [2285]	278 [2460]	160 [2320]	175 [2540]	240 [3480]
160	159 [9.7]	452	483	60 [16]	75 [20]	321 [2840]	362 [3205]	160 [2320]	175 [2540]	240 [3480]
200	190 [11.6]	367	385	60 [16]	75 [20]	380 [3365]	420 [3720]	150 [2180]	175 [2540]	240 [3480]
250	240 [14.6]	291	312	60 [16]	75 [20]	445 [3940]	557 [4930]	140 [2030]	175 [2540]	240 [3480]
315	303 [18.5]	228	245	60 [16]	75 [20]	460 [4071]	602 [5330]	120 [1740]	160 [2320]	200 [2900]
400	388 [23.7]	155	189	60 [16]	75 [20]	488 [4320]	625 [5532]	95 [1380]	125 [1810]	180 [2610]

► Performance data is typical. Performance of production units varies slightly from one motor to another. Running at intermittent ratings should not exceed 10% of every minute of operation.

DISPLACEMENT PERFORMANCE

		Pressure - bar [psi]			Max. Cont.		Max. Inter.	
025		30 [435]	60 [870]	80 [1160]	100 [1450]	120 [1740]	140 [2030]	
25 cm ³ [1.5 in ³] / rev								
		Torque - Nm [lb-in], Speed rpm				Intermittent Ratings - 10% of Operation		
Flow - lpm [gpm]	5 [1.3]	9 [80] 186	18 [159] 160	25 [221] 134	32 [283] 101	35 [310] 106		200
	10 [2.6]	10 [88] 386	18 [159] 352	26 [230] 323	34 [301] 280	37 [327] 255	48 [425] 210	400
	15 [4.0]	9 [80] 568	19 [168] 537	26 [230] 505	35 [310] 467	38 [336] 431	44 [389] 390	600
	20 [5.3]	8 [71] 777	19 [168] 736	25 [221] 692	33 [292] 660	39 [345] 608	45 [398] 566	800
	25 [6.6]	7 [62] 972	18 [159] 920	26 [230] 870	32 [283] 840	39 [345] 803	45 [398] 756	1000
	30 [7.9]	6 [53] 1167	17 [150] 1122	25 [221] 1088	32 [283] 1055	39 [345] 998	44 [389] 976	1200
	35 [9.2]	5 [44] 1360	16 [142] 1318	24 [212] 1282	31 [274] 1258	37 [327] 1216	43 [381] 1160	1400
	40 [10.6]	5 [44] 1570	15 [133] 1503	22 [195] 1476	31 [274] 1432	36 [319] 1394	41 [363] 1359	1600
	45 [11.9]		13 [115] 1687	20 [177] 1636	28 [248] 1600	34 [301] 1558	39 [345] 1516	1800
	Max. Max. Inter. Cont.							
Rotor Width		Overall Efficiency - 70 - 100% <input type="checkbox"/> 40 - 69% <input type="checkbox"/> 0 - 39% <input checked="" type="checkbox"/>						
4.1 [160] mm [in]		Theoretical Torque - Nm [lb-in]						
		12 [106]	24 [211]	32 [282]	40 [352]	48 [423]	56 [493]	
Displacement tested at 45°C [113°F] with an oil viscosity of 46cSt [213 SUS]								

		Pressure - bar [psi]			Max. Cont.		Max. Inter.	
032		30 [435]	60 [870]	80 [1160]	100 [1450]	120 [1740]	140 [2030]	
32 cm ³ [2.0 in ³] / rev								
		Torque - Nm [lb-in], Speed rpm				Intermittent Ratings - 10% of Operation		
Flow - lpm [gpm]	5 [1.3]	11 [97] 149	24 [212] 135	35 [310] 114	37 [327] 94			156
	10 [2.6]	12 [106] 308	27 [239] 284	37 [327] 270	43 [381] 250	46 [407] 240	56 [496] 211	313
	15 [4.0]	11 [97] 465	26 [230] 444	36 [319] 429	45 [398] 398	48 [425] 378	57 [504] 355	469
	20 [5.3]	10 [88] 624	25 [221] 589	35 [310] 575	44 [389] 557	46 [407] 544	56 [496] 524	625
	25 [6.6]	9 [80] 780	24 [212] 771	34 [301] 751	42 [372] 735	45 [398] 719	54 [478] 695	781
	30 [7.9]	8 [71] 931	23 [204] 908	32 [283] 895	40 [354] 876	45 [398] 857	52 [460] 822	938
	35 [9.2]	7 [62] 1086	20 [177] 1066	29 [257] 1051	39 [345] 1030	43 [381] 1012	51 [451] 981	1094
	40 [10.6]	7 [62] 1240	19 [168] 1212	27 [239] 1190	38 [336] 1178	43 [381] 1145	50 [442] 1121	1250
	45 [11.9]	6 [53] 1400	18 [159] 1382	26 [230] 1366	35 [310] 1340	42 [372] 1314	48 [425] 1280	1406
	50 [13.2]	5 [44] 1550	16 [142] 1526	24 [212] 1500	31 [274] 1478	40 [354] 1452	46 [407] 1418	1563
55 [14.5]		12 [106] 1674	20 [177] 1641	28 [248] 1617	34 [301] 1584	39 [345] 1555	1719	
Max. Max. Inter. Cont.								
Rotor Width		Overall Efficiency - 70 - 100% <input type="checkbox"/> 40 - 69% <input type="checkbox"/> 0 - 39% <input checked="" type="checkbox"/>						
5.1 [200] mm [in]		Theoretical Torque - Nm [lb-in]						
		15 [135]	31 [271]	41 [361]	51 [451]	61 [541]	71 [631]	
Displacement tested at 45°C [113°F] with an oil viscosity of 46cSt [213 SUS]								

► Performance data is typical. Performance of production units varies slightly from one motor to another. Operating at maximum continuous pressure and maximum continuous flow simultaneously is not recommended. For additional information on product testing please refer to page 6.

DISPLACEMENT PERFORMANCE

040		Pressure - bar [psi]					Max. Cont.	Max. Inter.
		30 [435]	60 [870]	80 [1160]	100 [1450]	120 [1740]	140 [2030]	
40 cm ³ [2.5 in ³] / rev		Torque - Nm [lb-in], Speed rpm					Intermittent Ratings - 10% of Operation	
Flow - lpm [gpm]	5 [1.3]	15 [133] 113	31 [274] 98	38 [336] 83	48 [425] 60	56 [496] 48		125
	10 [2.6]	14 [124] 238	31 [274] 222	41 [363] 204	54 [478] 182	62 [549] 161	70 [619] 114	250
	20 [5.3]	13 [115] 482	32 [283] 458	41 [363] 442	53 [469] 423	65 [575] 402	74 [655] 381	500
	30 [7.9]	12 [106] 730	30 [265] 704	39 [345] 687	51 [451] 668	63 [558] 646	74 [655] 624	750
	40 [10.6]	10 [88] 968	27 [239] 949	39 [345] 928	51 [451] 908	61 [540] 892	72 [637] 870	1000
	50 [13.2]	7 [62] 1219	25 [221] 1191	37 [327] 1173	49 [434] 1150	59 [522] 1127	71 [628] 1107	1250
	60 [15.8]	4 [35] 1471	23 [204] 1428	34 [301] 1411	46 [407] 1387	56 [496] 1369	68 [602] 1341	1500
Max. Inter. Cont.	70 [18.5]	16 [142] 1670	30 [265] 1653	41 [363] 1627	52 [460] 1612	64 [566] 1598	2000	
Rotor Width		Overall Efficiency - 70 - 100% <input type="checkbox"/> 40 - 69% <input type="checkbox"/> 0 - 39% <input type="checkbox"/>						
6.6 [260] mm [in]		Theoretical Torque - Nm [lb-in]						
		19 [168]	38 [336]	50 [442]	64 [566]	76 [673]	89 [788]	
		Displacement tested at 45°C [113°F] with an oil viscosity of 46cSt [213 SUS]						

050		Pressure - bar [psi]					Max. Cont.	Max. Inter.	
		30 [435]	60 [870]	80 [1160]	100 [1450]	120 [1740]	140 [2030]	160 [2320]	175 [2540]
50 cm ³ [3.0 in ³] / rev		Torque - Nm [lb-in], Speed rpm					Intermittent Ratings - 10% of Operation		
Flow - lpm [gpm]	5 [1.3]	19 [168] 100	39 [345] 85	48 [425] 75	62 [549] 64	75 [664] 48		101	
	10 [2.6]	20 [177] 197	38 [336] 196	50 [442] 174	63 [558] 159	78 [690] 146	92 [814] 127	102 [903] 101	107 [947] 97
	20 [5.3]	18 [159] 400	38 [336] 386	52 [460] 371	64 [566] 355	78 [690] 341	90 [796] 314	104 [920] 292	108 [956] 290
	30 [7.9]	15 [133] 600	37 [327] 585	50 [442] 571	64 [566] 560	77 [681] 540	89 [788] 516	103 [912] 499	107 [947] 495
	40 [10.6]	12 [106] 808	31 [274] 800	45 [398] 790	59 [522] 770	73 [646] 766	87 [770] 733	99 [876] 703	106 [938] 697
	50 [13.2]	9 [80] 1009	27 [239] 1006	41 [363] 986	55 [487] 982	68 [602] 964	84 [743] 956	98 [867] 930	105 [929] 872
	60 [15.8]	6 [53] 1208	24 [212] 1200	37 [327] 1196	53 [469] 1188	64 [566] 1176	82 [726] 1160	95 [841] 1140	102 [903] 963
Max. Inter. Cont.	70 [18.5]	3 [27] 1410	17 [150] 1396	32 [283] 1382	44 [389] 1370	58 [513] 1358	80 [708] 1347	93 [823] 1334	98 [867] 1315
Max. Inter.	75 [19.8]	15 [133] 1500	30 [265] 1488	40 [354] 1473	56 [496] 1457	77 [681] 1439	88 [779] 1412	93 [823] 1388	1515
Rotor Width		Overall Efficiency - 70 - 100% <input type="checkbox"/> 40 - 69% <input type="checkbox"/> 0 - 39% <input type="checkbox"/>							
6.6 [260] mm [in]		Theoretical Torque - Nm [lb-in]							
		24 [212]	47 [416]	63 [558]	79 [699]	95 [841]	110 [973]	126 [1115]	138 [1221]
		Displacement tested at 45°C [113°F] with an oil viscosity of 46cSt [213 SUS]							

► Performance data is typical. Performance of production units varies slightly from one motor to another. Operating at maximum continuous pressure and maximum continuous flow simultaneously is not recommended. For additional information on product testing please refer to page 6.

DISPLACEMENT PERFORMANCE

060		Pressure - bar [psi]						Max. Cont.	Max. Inter.	
		30 [435]	60 [870]	80 [1160]	100 [1450]	120 [1740]	140 [2030]	160 [2320]	175 [2540]	
59 cm ³ [3.6 in ³] / rev										
Max. Cont.		Torque - Nm [lb-in], Speed rpm						Intermittent Ratings - 10% of Operation		
		20 [177]	46 [407]	65 [575]	80 [708]	95 [841]	112 [991]			
Max. Inter.	5 [1.3]	83	79	72	64	51	38		85	
	10 [2.6]	22 [195]	47 [416]	66 [584]	81 [717]	96 [850]	113 [1000]	125 [1106]	136 [1204]	170
	20 [5.3]	169	164	155	142	135	124	108	88	339
	30 [7.9]	20 [177]	45 [398]	64 [566]	80 [708]	93 [823]	111 [982]	123 [1088]	134 [1186]	509
	40 [10.6]	338	332	320	309	290	276	245	222	678
	50 [13.2]	17 [150]	43 [381]	62 [549]	76 [673]	89 [788]	109 [965]	121 [1071]	131 [1159]	848
	60 [15.8]	507	502	493	482	468	454	424	400	1017
	70 [18.5]	14 [124]	41 [363]	58 [513]	73 [646]	87 [770]	105 [929]	117 [1035]	127 [1124]	1186
75 [19.8]	678	669	660	645	630	616	594	582	1271	
Max. Cont.		10 [88]	37 [327]	55 [487]	70 [619]	84 [743]	102 [903]	113 [1000]	122 [1080]	
Max. Inter.		7 [62]	34 [301]	52 [460]	66 [584]	82 [726]	99 [876]	109 [965]	118 [1044]	
		4 [35]	27 [239]	47 [416]	62 [549]	76 [673]	93 [823]	104 [920]	114 [1009]	
		1185	1182	1180	1175	1158	1144	1128	1112	
			22 [195]	43 [381]	58 [513]	73 [646]	86 [761]	100 [885]	110 [973]	
			1271	1265	1256	1241	1228	1212	1196	
Rotor Width		Overall Efficiency - 70 - 100% <input type="checkbox"/> 40 - 69% <input type="checkbox"/> 0 - 39% <input checked="" type="checkbox"/>								
8.0 [314] mm [in]		Theoretical Torque - Nm [lb-in]								
		28 [249]	56 [499]	75 [665]	94 [831]	113 [998]	132 [1164]	150 [1330]	164 [1455]	
Displacement tested at 45°C [113°F] with an oil viscosity of 46cSt [213 SUS]										

080		Pressure - bar [psi]						Max. Cont.	Max. Inter.	
		30 [435]	60 [870]	80 [1160]	100 [1450]	120 [1740]	140 [2030]	160 [2320]	175 [2540]	
78 cm ³ [4.8 in ³] / rev										
Max. Cont.		Torque - Nm [lb-in], Speed rpm						Intermittent Ratings - 10% of Operation		
		32 [283]	62 [549]	80 [708]	106 [938]	125 [1106]				
Max. Inter.	5 [1.3]	60	56	50	42	30			64	
	10 [2.6]	31 [274]	64 [566]	84 [743]	104 [920]	120 [1062]	142 [1257]	162 [1434]	175 [1549]	128
	20 [5.3]	125	118	112	104	98	82	67	50	256
	30 [7.9]	26 [230]	60 [531]	84 [743]	102 [903]	125 [1106]	144 [1274]	164 [1451]	183 [1619]	385
	40 [10.6]	254	245	236	228	215	204	190	175	513
	50 [13.2]	24 [212]	56 [496]	81 [717]	100 [885]	122 [1080]	142 [1257]	160 [1416]	175 [1549]	641
	60 [15.8]	384	374	366	358	346	335	318	305	769
	70 [18.5]	19 [168]	53 [469]	75 [664]	96 [850]	118 [1044]	140 [1239]	158 [1398]	170 [1504]	897
75 [19.8]	512	505	494	483	473	462	450	438	962	
Max. Cont.		14 [124]	46 [407]	70 [619]	92 [814]	110 [973]	135 [1195]	156 [1381]	168 [1487]	
Max. Inter.		10 [88]	42 [372]	66 [584]	86 [761]	106 [938]	128 [1133]	150 [1327]	164 [1451]	
		768	762	756	748	738	728	717	694	
		6 [53]	36 [319]	56 [496]	78 [690]	98 [867]	118 [1044]	140 [1239]	160 [1416]	
		896	890	882	872	860	846	830	816	
		3 [27]	27 [239]	50 [442]	74 [655]	92 [814]	113 [1000]	133 [1177]	148 [1310]	
		960	955	948	938	926	916	896	802	
Rotor Width		Overall Efficiency - 70 - 100% <input type="checkbox"/> 40 - 69% <input type="checkbox"/> 0 - 39% <input checked="" type="checkbox"/>								
10.4 [410] mm [in]		Theoretical Torque - Nm [lb-in]								
		37 [327]	75 [664]	100 [885]	125 [1106]	149 [1319]	174 [1540]	199 [1761]	218 [1929]	
Displacement tested at 45°C [113°F] with an oil viscosity of 46cSt [213 SUS]										

► Performance data is typical. Performance of production units varies slightly from one motor to another. Operating at maximum continuous pressure and maximum continuous flow simultaneously is not recommended. For additional information on product testing please refer to page 6.

DISPLACEMENT PERFORMANCE

		Pressure - bar [psi]						Max. Cont.	Max. Inter.			
100		30 [435]	60 [870]	80 [1160]	100 [1450]	120 [1740]	140 [2030]	160 [2320]	175 [2540]			
96 cm ³ [5.9 in ³] / rev		Torque - Nm [lb-in], Speed rpm						Intermittent Ratings - 10% of Operation				
Flow - lpm [gpm]	5 [1.3]	43 [381] 51	82 [726] 42	109 [965] 35	131 [1159] 25						52	Theoretical rpm
	10 [2.6]	43 [381] 99	84 [743] 93	108 [956] 84	133 [1177] 72	152 [1345] 62	180 [1593] 48	197 [1743] 24			104	
	20 [5.3]	41 [363] 205	79 [699] 202	107 [947] 197	127 [1124] 192	154 [1363] 182	178 [1575] 172	200 [1770] 140	212 [1876] 118		208	
	30 [7.9]	39 [345] 311	74 [655] 307	101 [894] 301	126 [1115] 294	152 [1345] 283	176 [1558] 271	198 [1752] 258	213 [1885] 240		313	
	40 [10.6]	29 [257] 413	63 [558] 410	93 [823] 406	121 [1071] 399	150 [1327] 388	172 [1522] 379	195 [1726] 368	208 [1841] 347		417	
	50 [13.2]	20 [177] 519	52 [460] 515	85 [752] 510	115 [1018] 503	148 [1310] 492	169 [1496] 480	193 [1708] 464	203 [1796] 446		521	
	60 [15.8]	17 [150] 624	53 [469] 620	83 [735] 615	111 [982] 608	138 [1221] 600	165 [1460] 582	183 [1619] 565	193 [1708] 548		625	
	70 [18.5]	11 [97] 728	42 [372] 726	73 [646] 723	93 [823] 714	126 [1115] 706	159 [1407] 684	172 [1522] 668	183 [1619] 646		729	
Max. Inter.	75 [19.8]	6 [53] 780	35 [310] 771	61 [540] 764	89 [788] 755	118 [1044] 736	145 [1283] 724	156 [1381] 712	176 [1558] 699		781	
Rotor Width		Overall Efficiency - 70 - 100% <input type="checkbox"/> 40 - 69% <input type="checkbox"/> 0 - 39% <input type="checkbox"/>										
13.0 [510]		Theoretical Torque - Nm [lb-in]										
mm [in]		46 [407]	92 [814]	122 [1080]	153 [1354]	183 [1623]	214 [1894]	245 [2168]	268 [2372]			
Displacement tested at 45°C [113°F] with an oil viscosity of 46cSt [213 SUS]												

		Pressure - bar [psi]						Max. Cont.	Max. Inter.			
125		30 [435]	60 [870]	80 [1160]	100 [1450]	120 [1740]	140 [2030]	160 [2320]	175 [2540]			
125 cm ³ [7.6 in ³] / rev		Torque - Nm [lb-in], Speed rpm						Intermittent Ratings - 10% of Operation				
Flow - lpm [gpm]	5 [1.3]	52 [460] 38	95 [841] 35	135 [1195] 32	168 [1487] 27						40	Theoretical rpm
	10 [2.6]	50 [442] 78	98 [867] 74	138 [1221] 69	172 [1522] 62	190 [1681] 54	234 [2071] 45	258 [2283] 35			80	
	20 [5.3]	50 [442] 158	96 [850] 152	132 [1168] 144	168 [1487] 135	202 [1788] 124	236 [2088] 110	256 [2265] 94	278 [2460] 78		160	
	30 [7.9]	44 [389] 238	92 [814] 232	126 [1115] 225	164 [1451] 215	198 [1752] 210	232 [2053] 198	262 [2319] 168	268 [2372] 155		240	
	40 [10.6]	35 [310] 319	82 [726] 316	118 [1044] 312	160 [1416] 308	193 [1708] 300	226 [2000] 288	252 [2230] 262	266 [2354] 238		320	
	50 [13.2]	31 [274] 399	77 [681] 396	108 [956] 392	155 [1372] 383	182 [1611] 368	220 [1947] 354	238 [2106] 338	262 [2319] 326		400	
	60 [15.8]	15 [133] 479	64 [566] 478	97 [858] 475	146 [1292] 470	166 [1469] 463	210 [1858] 454	224 [1982] 443	256 [2265] 434		480	
	70 [18.5]	8 [71] 559	50 [442] 555	90 [796] 548	140 [1239] 538	162 [1434] 524	204 [1805] 516	209 [1850] 500	236 [2088] 488		560	
Max. Inter.	75 [19.8]	40 [354] 599	71 [628] 594	128 [1133] 588	158 [1398] 576	192 [1699] 565	199 [1761] 536	224 [1982] 524		600		
Rotor Width		Overall Efficiency - 70 - 100% <input type="checkbox"/> 40 - 69% <input type="checkbox"/> 0 - 39% <input type="checkbox"/>										
16.8 [660]		Theoretical Torque - Nm [lb-in]										
mm [in]		60 [531]	119 [1053]	159 [1407]	199 [1761]	239 [2115]	279 [2469]	318 [2814]	348 [3080]			
Displacement tested at 45°C [113°F] with an oil viscosity of 46cSt [213 SUS]												

► Performance data is typical. Performance of production units varies slightly from one motor to another. Operating at maximum continuous pressure and maximum continuous flow simultaneously is not recommended. For additional information on product testing please refer to page 6.

DISPLACEMENT PERFORMANCE

160		Pressure - bar [psi]						Max. Cont.	Max. Inter.		
		30 [435]	60 [870]	80 [1160]	100 [1450]	120 [1740]	140 [2030]	160 [2320]	175 [2540]		
159 cm ³ [9.7 in ³] / rev		Torque - Nm [lb-in], Speed rpm						Intermittent Ratings - 10% of Operation			
Max. Cont.	Flow - lpm [gpm]	5 [1.3]	56 [496]	112 [991]	154 [1363]	201 [1779]				Theoretical rpm	
		10 [2.6]	30	25	18	10					
		20 [5.3]	58 [513]	115 [1018]	156 [1381]	205 [1814]	245 [2168]	285 [2522]			
		30 [7.9]	63	60	56	52	48	37			
		40 [10.6]	60 [532]	123 [1089]	162 [1434]	202 [1788]	242 [2142]	282 [2496]	327 [2894]		360 [3186]
		50 [13.2]	128	125	121	116	110	100	86		78
		60 [15.8]	50 [443]	117 [1035]	157 [1389]	197 [1743]	238 [2106]	278 [2460]	322 [2850]		358 [3168]
		70 [18.5]	193	190	187	183	179	173	160		144
Max. Inter.	Flow - lpm [gpm]	40 [10.6]	48 [425]	113 [1000]	155 [1372]	195 [1726]	236 [2089]	273 [2416]	318 [2814]	355 [3142]	
		50 [13.2]	257	255	252	248	244	239	224	211	
		60 [15.8]	32 [283]	106 [938]	149 [1319]	188 [1664]	235 [2080]	267 [2363]	313 [2770]	352 [3115]	
Max. Inter.	Flow - lpm [gpm]	70 [18.5]	323	320	316	312	306	299	288	275	
		75 [19.8]	23 [204]	88 [779]	133 [1177]	178 [1575]	212 [1876]	260 [2301]	308 [2726]	342 [3027]	
		75 [19.8]	483	481	477	472	466	460	450	436	
Rotor Width		Overall Efficiency - 70 - 100% <input type="checkbox"/> 40 - 69% <input type="checkbox"/> 0 - 39% <input checked="" type="checkbox"/>									
20.8 [820] mm [in]		Theoretical Torque - Nm [lb-in]									
		74 [651]	147 [1302]	196 [1736]	245 [2170]	282 [2496]	343 [3038]	392 [3472]	429 [3798]		
		Displacement tested at 45°C [113°F] with an oil viscosity of 46cSt [213 SUS]									

200		Pressure - bar [psi]						Max. Cont.	Max. Inter.		
		30 [435]	60 [870]	80 [1160]	100 [1450]	115 [1670]	140 [2030]	150 [2180]	175 [2540]		
190 cm ³ [11.6 in ³] / rev		Torque - Nm [lb-in], Speed rpm						Intermittent Ratings - 10% of Operation			
Max. Cont.	Flow - lpm [gpm]	5 [1.3]	75 [664]	158 [1398]	200 [1770]	241 [2133]				Theoretical rpm	
		10 [2.6]	25	22	20	10					
		20 [5.3]	78 [690]	160 [1416]	204 [1805]	252 [2230]	291 [2575]	348 [3080]	377 [3336]		
		30 [7.9]	51	49	45	39	35	29	22		
		40 [10.6]	74 [655]	156 [1381]	200 [1770]	246 [2177]	293 [2593]	354 [3133]	380 [3363]		416 [3681]
		50 [13.2]	104	102	99	95	89	83	76		65
		60 [15.8]	70 [619]	152 [1345]	196 [1735]	240 [2124]	290 [2566]	352 [3115]	378 [3345]		420 [3717]
		70 [18.5]	157	155	152	148	143	137	130		118
Max. Inter.	Flow - lpm [gpm]	40 [10.6]	65 [575]	147 [1301]	190 [1681]	228 [2018]	286 [2531]	340 [3009]	376 [3327]	418 [3699]	
		50 [13.2]	210	208	205	200	193	186	178	168	
		60 [15.8]	54 [478]	142 [1257]	180 [1593]	222 [1965]	277 [2451]	333 [2947]	356 [3150]	402 [3558]	
Max. Inter.	Flow - lpm [gpm]	70 [18.5]	262	260	258	254	249	243	235	223	
		75 [19.8]	36 [319]	128 [1133]	166 [1469]	210 [1858]	266 [2354]	322 [2850]	350 [3097]	400 [3540]	
		75 [19.8]	315	313	309	305	299	293	284	268	
Rotor Width		Overall Efficiency - 70 - 100% <input type="checkbox"/> 40 - 69% <input type="checkbox"/> 0 - 39% <input checked="" type="checkbox"/>									
25.9 [1.020] mm [in]		Theoretical Torque - Nm [lb-in]									
		91 [803]	182 [1611]	242 [2142]	303 [2677]	348 [3079]	424 [3748]	454 [4016]	529 [4685]		
		Displacement tested at 45°C [113°F] with an oil viscosity of 46cSt [213 SUS]									

► Performance data is typical. Performance of production units varies slightly from one motor to another. Operating at maximum continuous pressure and maximum continuous flow simultaneously is not recommended. For additional information on product testing please refer to page 6.

DISPLACEMENT PERFORMANCE

		Pressure - bar [psi]				Max. Cont.		Max. Inter.	
250		30 [435]	60 [870]	85 [1230]	100 [1450]	125 [1810]	140 [2030]	160 [2320]	175 [2540]
240 cm ³ [14.6 in ³] / rev		Torque - Nm [lb-in], Speed rpm						Intermittent Ratings - 10% of Operation	
Flow - lpm [gpm]	5 [1.3]	89 [788] 19	194 [1717] 16	264 [2336] 10	326 [2885] 6				21
	10 [2.6]	92 [814] 40	196 [1735] 36	268 [2372] 32	329 [2912] 21	394 [3487] 10			42
Max. Cont.	20 [5.3]	90 [796] 81	192 [1699] 77	264 [2336] 72	321 [2841] 65	397 [3513] 50	445 [3938] 42	510 [4513] 36	554 [4903] 23
	30 [7.9]	86 [761] 124	185 [1637] 121	256 [2265] 115	314 [2779] 106	392 [3469] 94	439 [3855] 84	502 [4442] 76	557 [4929] 61
Max. Inter.	40 [10.6]	82 [726] 165	179 [1584] 162	248 [2195] 158	305 [2699] 153	384 [3398] 144	431 [3814] 135	486 [4301] 125	545 [4823] 113
	50 [13.2]	69 [611] 207	169 [1496] 203	243 [2150] 195	293 [2593] 189	378 [3345] 183	421 [3726] 170	475 [4204] 157	526 [4655] 138
Max. Inter.	60 [15.8]	48 [425] 250	152 [1345] 247	230 [2035] 243	282 [2496] 236	364 [3221] 222	407 [3602] 216	456 [4035] 205	508 [4496] 188
	70 [18.5]	37 [327] 291	139 [1230] 285	219 [1938] 278	263 [2327] 271	343 [3035] 256	386 [3416] 249	441 [3903] 234	496 [4389] 221
Max. Inter.	75 [19.8]	26 [230] 312	128 [1133] 310	205 [1814] 307	245 [2168] 302	328 [2903] 294	374 [3310] 270	428 [3788] 254	481 [4257] 242
	Rotor Width		Overall Efficiency - 70 - 100% <input type="checkbox"/> 40 - 69% <input type="checkbox"/> 0 - 39% <input type="checkbox"/>						
32.5 [1.280] mm [in]		Theoretical Torque - Nm [lb-in]							
		115 [1018]	229 [2027]	325 [2875]	382 [3381]	478 [4230]	535 [4735]	611 [5407]	669 [5920]
		Displacement tested at 45°C [113°F] with an oil viscosity of 46cSt [213 SUS]							

		Pressure - bar [psi]				Max. Cont.		Max. Inter.	
315		30 [435]	50 [725]	70 [1015]	85 [1230]	100 [1450]	120 [1740]	140 [2030]	160 [2320]
303 cm ³ [18.5 in ³] / rev		Torque - Nm [lb-in], Speed rpm						Intermittent Ratings - 10% of Operation	
Flow - lpm [gpm]	5 [1.3]	123 [1089] 16	200 [1770] 13	282 [2496] 10	344 [3044] 6				17
	10 [2.6]	117 [1035] 31	194 [1717] 29	277 [2451] 25	342 [3027] 21	399 [3531] 17			33
Max. Cont.	20 [5.3]	112 [991] 64	196 [1735] 62	275 [2434] 58	340 [3009] 54	397 [3513] 49	460 [4071] 43	526 [4655] 32	605 [5354] 23
	30 [7.9]	104 [920] 98	183 [1620] 94	267 [2363] 90	322 [2850] 85	390 [3452] 79	448 [3965] 70	520 [4602] 62	602 [5328] 56
Max. Inter.	40 [10.6]	86 [761] 129	168 [1487] 126	252 [2230] 122	304 [2690] 118	365 [3230] 113	440 [3894] 106	515 [4558] 99	588 [5204] 76
	50 [13.2]	73 [646] 164	156 [1381] 160	238 [2106] 155	288 [2549] 150	350 [3098] 144	424 [3752] 136	500 [4425] 127	571 [5053] 119
Max. Inter.	60 [15.8]	60 [531] 195	140 [1239] 192	223 [1974] 188	270 [2390] 183	325 [2876] 176	396 [3505] 170	480 [4248] 164	546 [4832] 157
	70 [18.5]	37 [327] 228	122 [1080] 226	186 [1646] 223	254 [2248] 218	309 [2735] 212	368 [3257] 206	455 [4027] 196	527 [4664] 188
Max. Inter.	75 [19.8]	23 [204] 245	100 [885] 242	174 [1540] 238	237 [2097] 233	293 [2593] 228	359 [3177] 222	444 [3929] 215	516 [4567] 206
	Rotor Width		Overall Efficiency - 60 - 100% <input type="checkbox"/> 40 - 59% <input type="checkbox"/> 0 - 39% <input type="checkbox"/>						
40.9 [1.610] mm [in]		Theoretical Torque - Nm [lb-in]							
		145 [1283]	241 [2133]	338 [2991]	410 [3628]	482 [4265]	579 [5124]	675 [5973]	772 [6832]
		Displacement tested at 45°C [113°F] with an oil viscosity of 46cSt [213 SUS]							

► Performance data is typical. Performance of production units varies slightly from one motor to another. Operating at maximum continuous pressure and maximum continuous flow simultaneously is not recommended. For additional information on product testing please refer to page 6.

DISPLACEMENT PERFORMANCE

400		Pressure - bar [psi]						Max. Cont.		Max. Inter.			
		30 [435]	45 [650]	55 [800]	65 [940]	80 [1160]	95 [1380]	110 [1595]	125 [1810]				
388 cm ³ [23.7 in ³] / rev													
Torque - Nm [lb-in], Speed rpm						Intermittent Ratings - 10% of Operation							
Flow - lpm [gpm]	Max. Cont.	5 [1.3]	11	10	7	5						13	
		10 [2.6]	146 [1292]	223 [1973]	272 [2407]	340 [3009]	412 [3646]	488 [4319]				26	
		20 [5.3]	145 [1283]	219 [1938]	269 [2381]	333 [2347]	408 [3611]	484 [4283]	548 [4850]				52
		30 [7.9]	138 [1221]	215 [1903]	262 [2319]	322 [2850]	402 [3558]	472 [4177]	546 [4832]	625 [5531]			77
		40 [10.6]	120 [1062]	204 [1805]	250 [2212]	310 [2743]	393 [3478]	458 [4053]	535 [4735]	618 [5469]			103
		50 [13.2]	100 [885]	186 [1646]	238 [2106]	295 [2611]	374 [3310]	446 [3947]	520 [4602]	600 [5310]			129
		60 [15.8]	76 [673]	166 [1469]	222 [1965]	282 [2496]	358 [3168]	427 [3779]	496 [4389]	576 [5097]			155
		70 [18.5]	50 [442]	145 [1283]	194 [1717]	250 [2212]	334 [2956]	402 [3558]	472 [4177]	540 [4779]			180
Max. Inter.	75 [19.8]	42 [372]	135 [1195]	176 [1558]	226 [2000]	306 [2708]	373 [3301]	445 [3938]	520 [4602]			190	
		189	187	184	180	175	167	160	150				
Rotor Width 52.1 [2.050] mm [in]													
Overall Efficiency - 70 - 100% <input type="checkbox"/> 40 - 69% <input type="checkbox"/> 0 - 39% <input checked="" type="checkbox"/>													
Theoretical Torque - Nm [lb-in] 185 [1640] 278 [2460] 340 [3007] 402 [3554] 494 [4374] 587 [5194] 680 [6014] 772 [6834]													
Displacement tested at 45°C [113°F] with an oil viscosity of 46cSt [213 SUS]													

► Performance data is typical. Performance of production units varies slightly from one motor to another. Operating at maximum continuous pressure and maximum continuous flow simultaneously is not recommended. For additional information on product testing please refer to page 6.

HOUSINGS

► Dimensions shown are without paint. Paint thickness can be up to 0.13 [.005].

2-HOLE, SAE A MOUNT, ALIGNED PORTS

A10 1/2-14 NPT **A11** 7/8-14 UNF **A18** G 1/2 **A68** G 1/2 (TP)

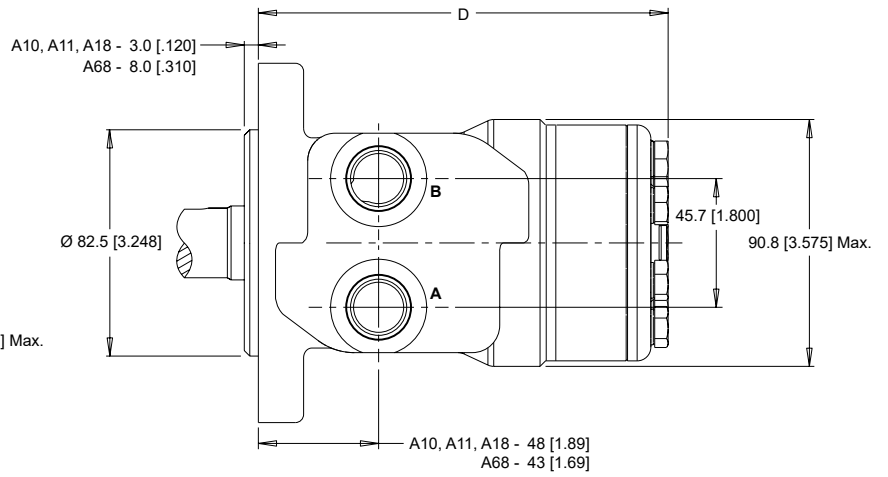
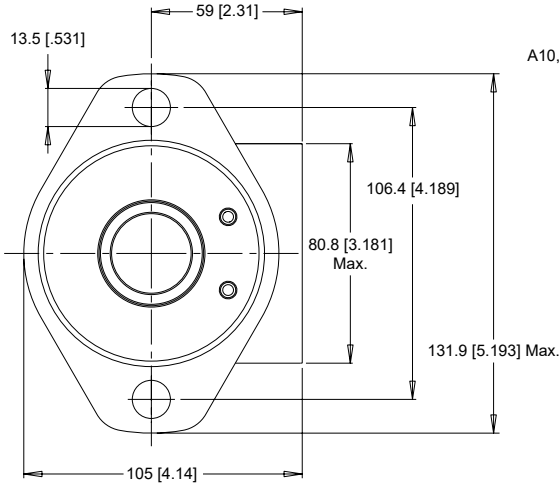

4-HOLE, MAGNETO MOUNT, ALIGNED PORTS

A30 1/2-14 NPT **A31** 7/8-14 UNF **AC8** G 1/2 (TP)

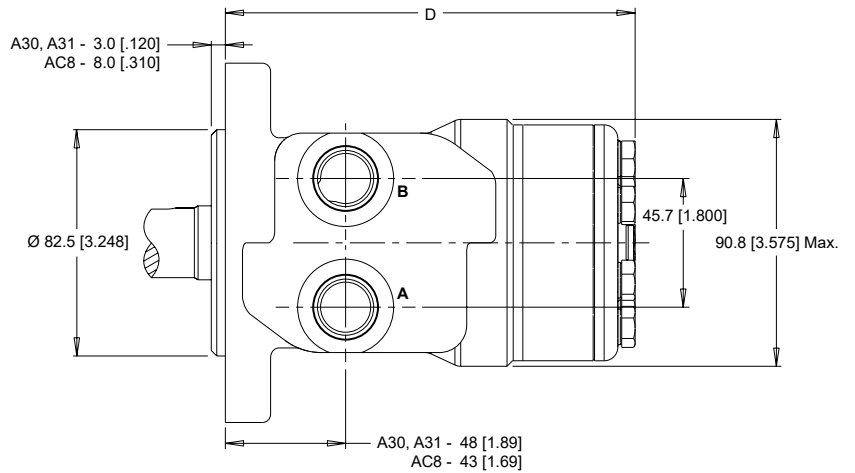
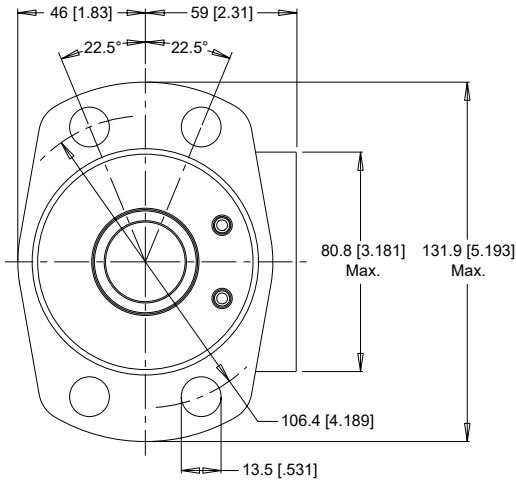

2-HOLE, SAE A MOUNT, OFFSET PORTS

A12 G 1/2 **A62** G 1/2 (TP) **A69** 7/8-14 UNF (TP)

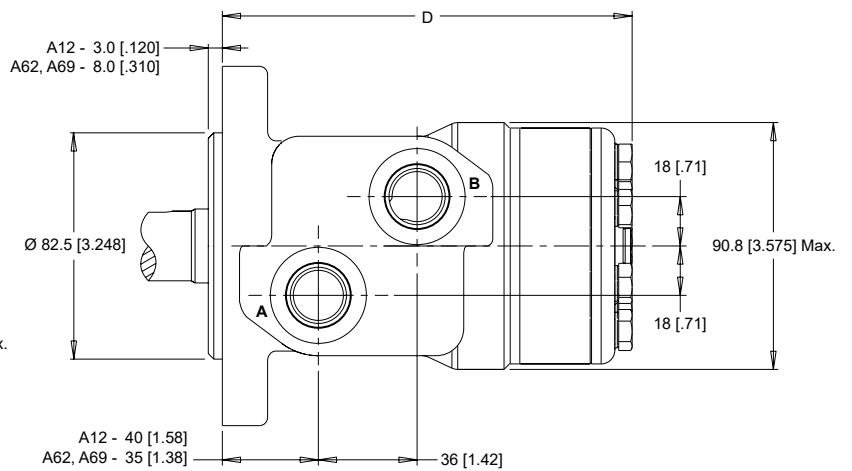
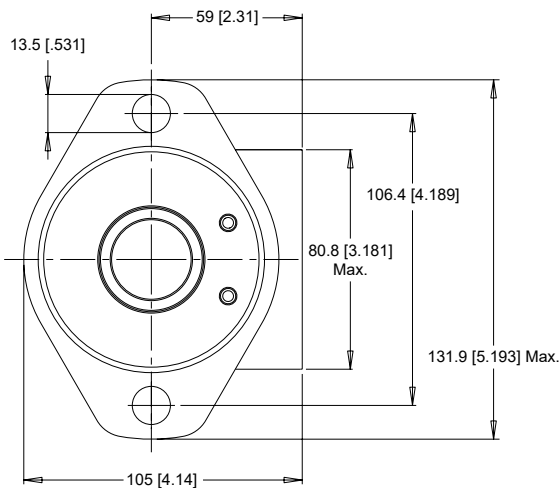

► Dimension D is charted on page 40. ► (TP) - Taller Pilot Height. Refer to detailed drawing for dimensional differences.

HOUSINGS

► Dimensions shown are without paint. Paint thickness can be up to 0.13 [.005].

4-HOLE, MAGNETO MOUNT, OFFSET PORTS

A32 G 1/2

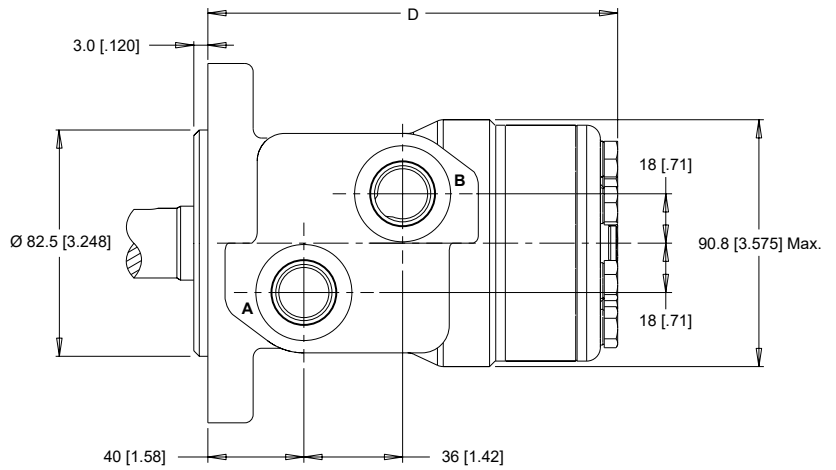
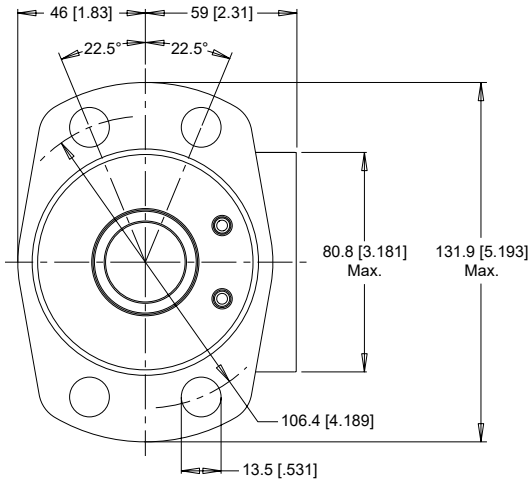

2-HOLE, SAE A MOUNT, ALIGNED MANIFOLD PORTS

A17 1/2" Drilled **G17** 1/2" Drilled

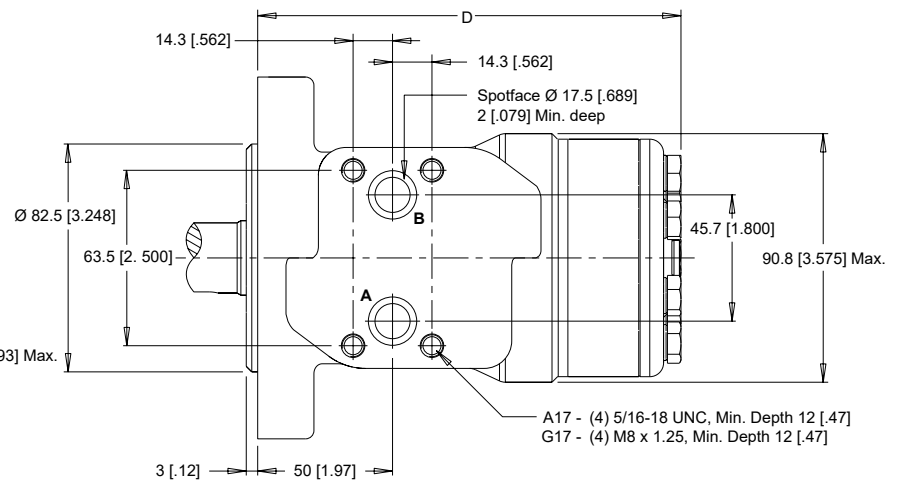
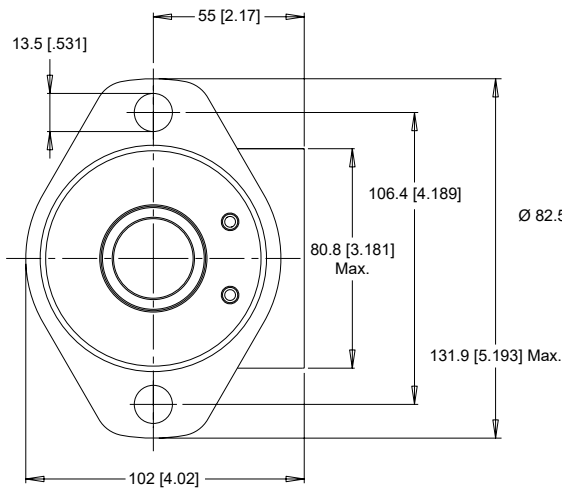

4-HOLE, MAGNETO MOUNT, ALIGNED MANIFOLD PORTS

A37 1/2" Drilled **AC7** 1/2" Drilled (TP)

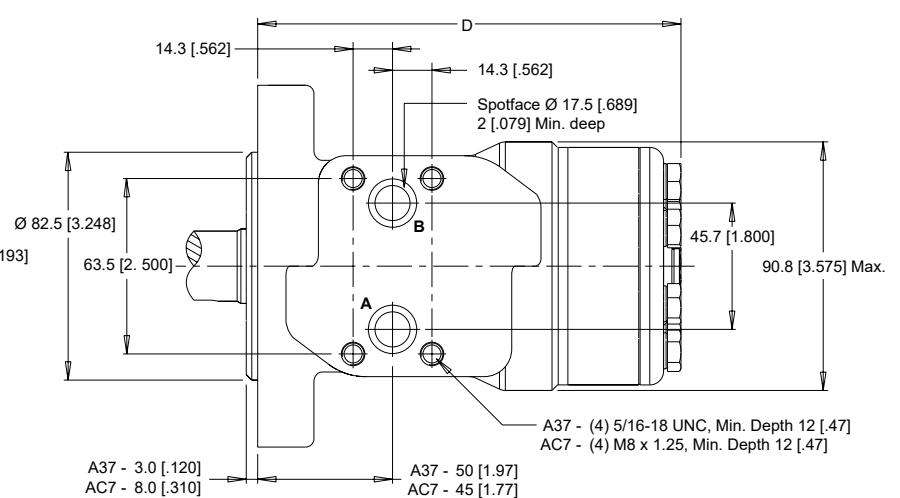
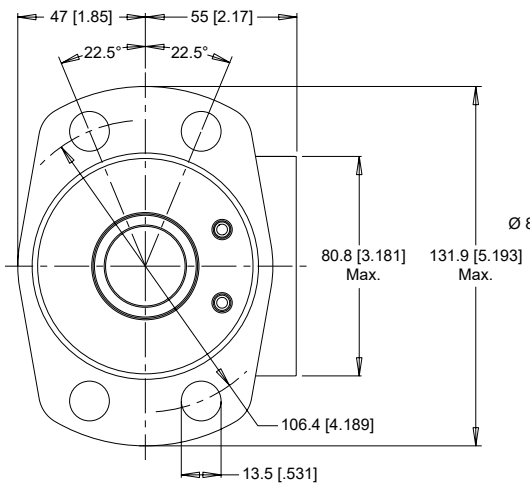

► Dimension D is charted on page 40. ► (TP) - Taller Pilot Height. Refer to detailed drawing for dimensional differences.

HOUSINGS

► Dimensions shown are without paint. Paint thickness can be up to 0.13 [.005].

2-HOLE, SAE A MOUNT, OFFSET MANIFOLD PORTS

A13 G 1/2

A63 G 1/2 (TP)

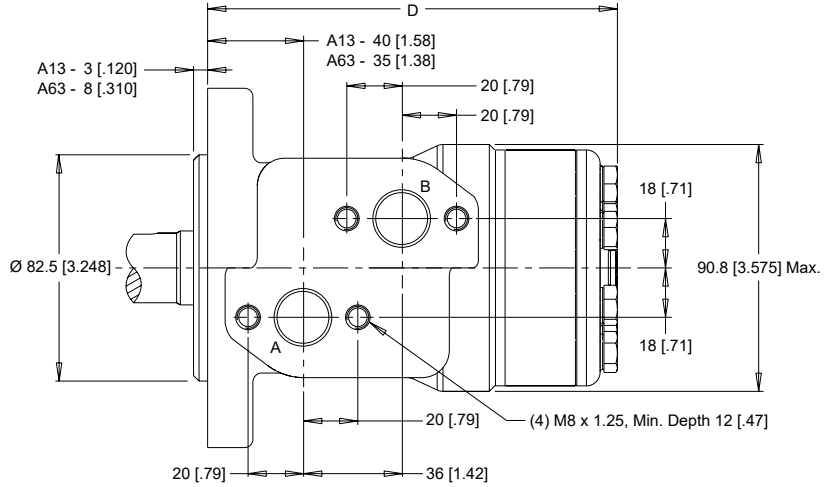
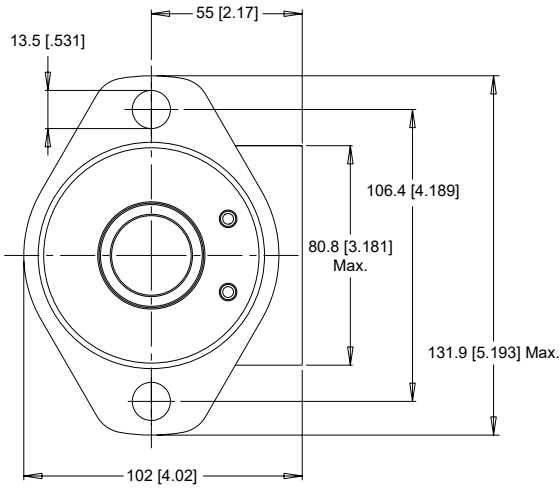

4-HOLE, MAGNETO MOUNT, OFFSET MANIFOLD PORTS

A3D 7/8-14 UNF

AC3 G 1/2 (TP)

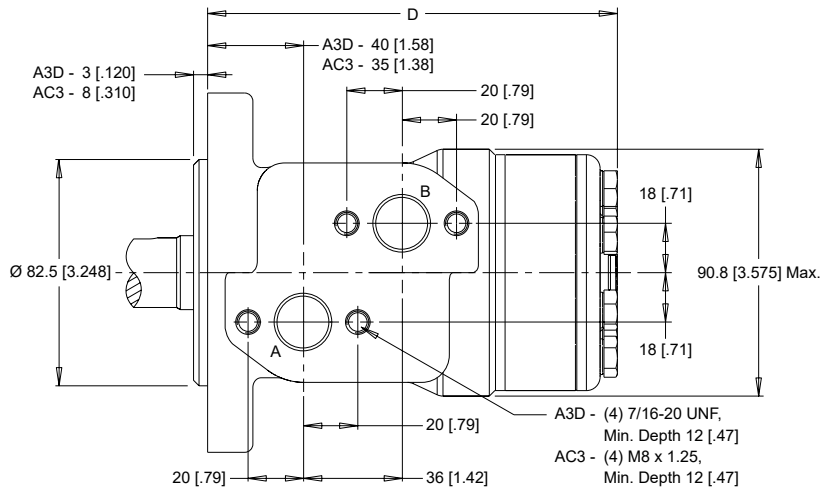
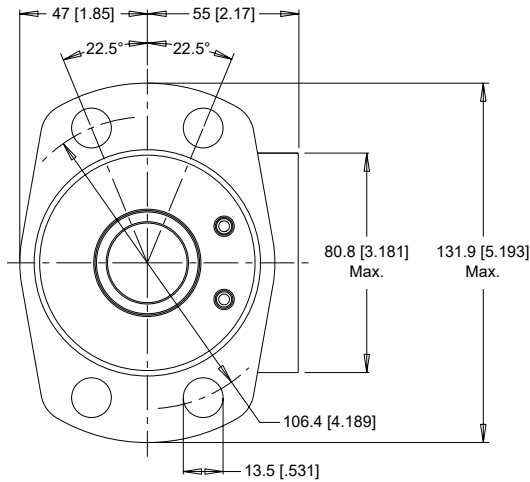

4-HOLE, SQUARE MOUNT, ALIGNED PORTS

F30 1/2-14 NPT

F31 7/8-14 UNF

F38 G 1/2

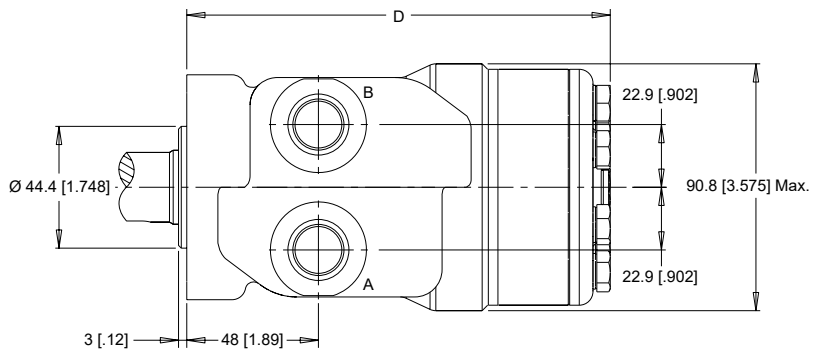
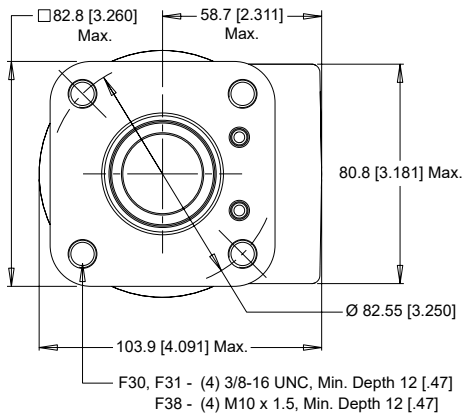

► Dimension D is charted on page 40. ► (TP) - Taller Pilot Height. Refer to detailed drawing for dimensional differences.

WP (155/156 Series)
Light Duty Hydraulic Motor

HOUSINGS

► Dimensions shown are without paint. Paint thickness can be up to 0.13 [.005].

4-HOLE, SQUARE MOUNT, ALIGNED MANIFOLD PORTS **F37** 1/2" Drilled

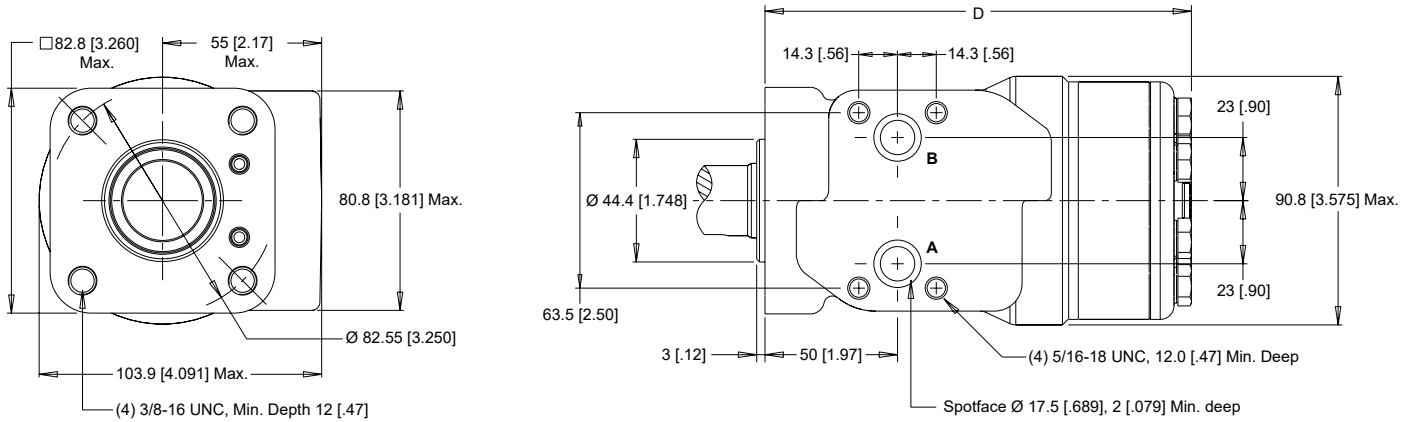

2-HOLE, SAE A MOUNT, OFFSET PORTS, VALVE CAVITY **A19** 7/8-14 UNF

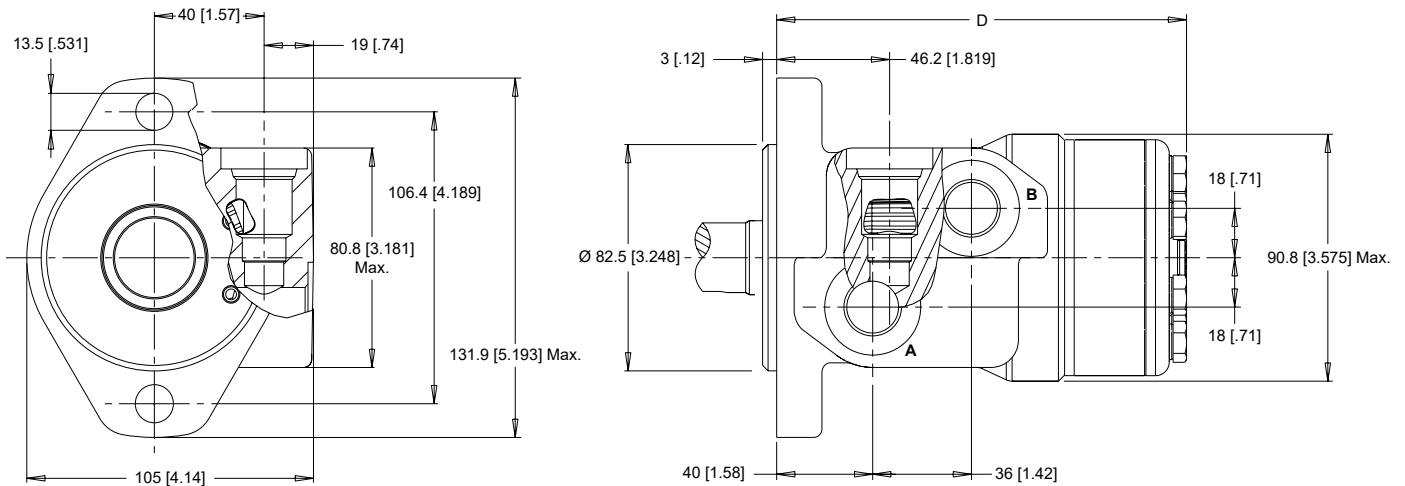

4-HOLE, MAGNETO MOUNT, OFFSET PORTS, VALVE CAVITY **A39** 7/8-14 UNF **AC2** G 1/2 (TP)

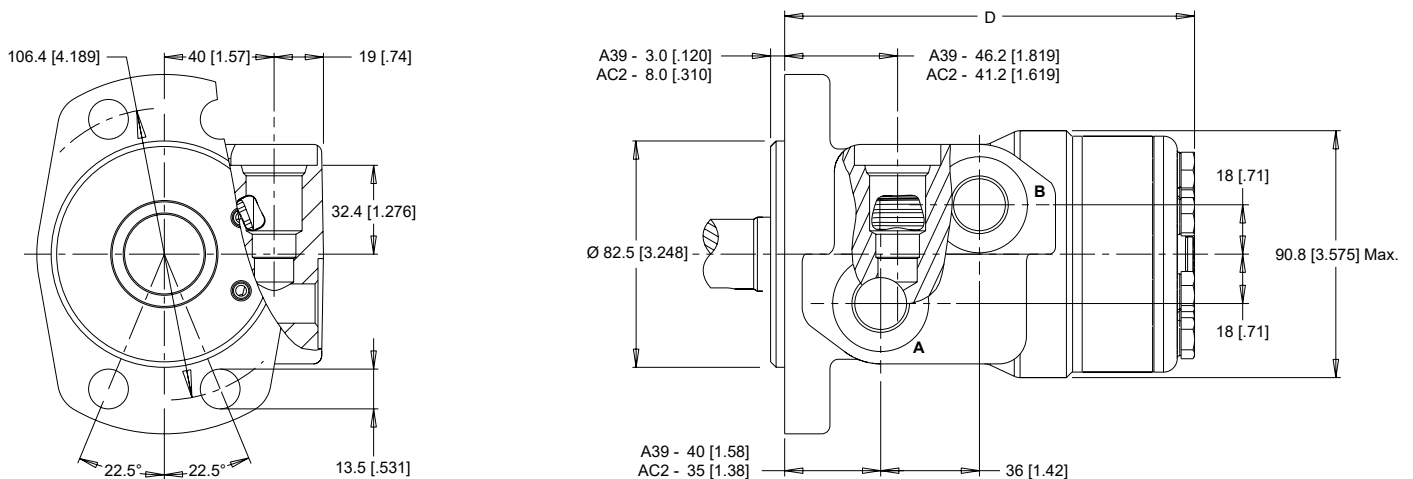

► Dimension D is charted on page 40. ► (TP) - Taller Pilot Height. Refer to detailed drawing for dimensional differences.

HOUSINGS

► Dimensions shown are without paint. Paint thickness can be up to 0.13 [.005].

2-HOLE, SAE A MOUNT, ALIGNED END PORTS

A06 3/4-16 UNF **A08** G 1/2 **AP6** 3/4-16 UNF (TP) **AP8** G 1/2 (TP)

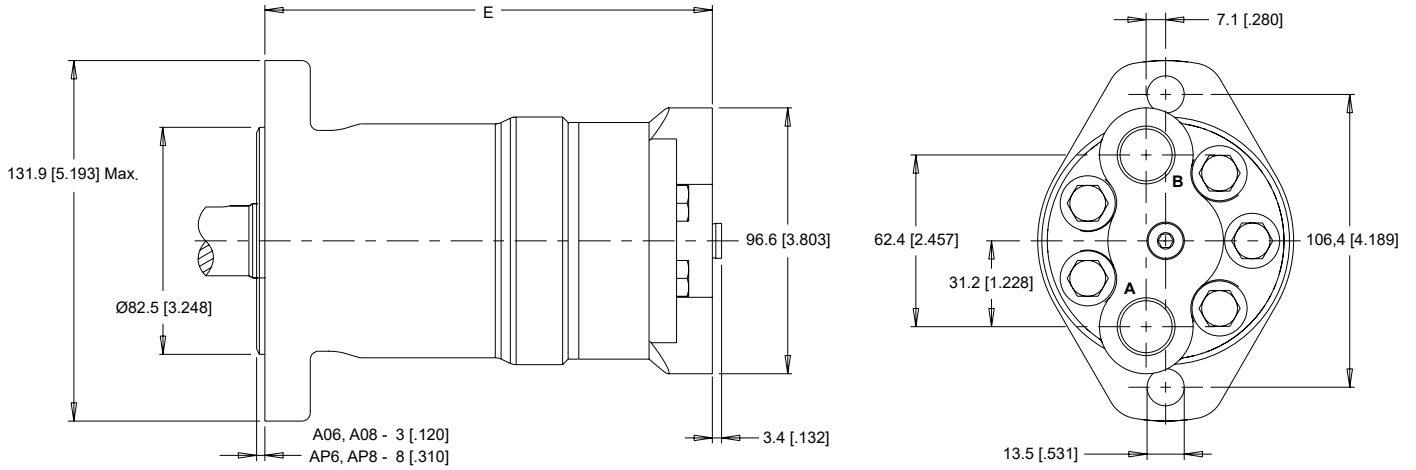

4-HOLE, SQUARE MOUNT, ALIGNED END PORTS

F21 7/8-14 UNF **F26** 3/4-16 UNF **G24** M22 x 1.5 **G28** G 1/2

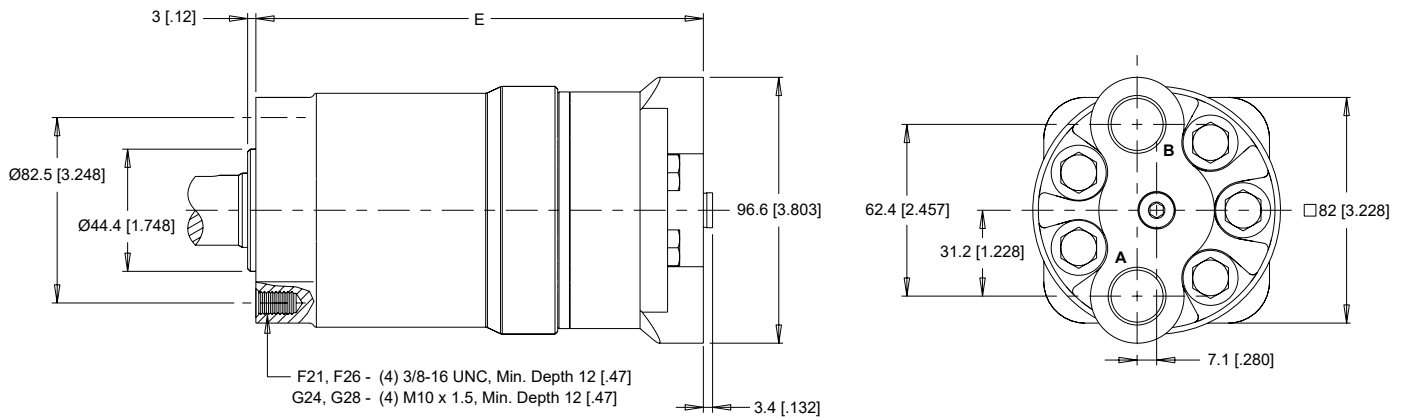

► Dimension E is charted on page 40. ► (TP) - Taller Pilot Height. Refer to detailed drawing for dimensional differences.

TECHNICAL INFORMATION

ALLOWABLE SHAFT LOAD / BEARING CURVE

The bearing curve below represents the side load capacity of the motor at the centerline of the key for various motor speeds. Operating conditions within the shaded area will maintain acceptable oil film lubrication with recommended fluids. Operating conditions outside the shaded area are susceptible to motor failure due to oil starvation and/or excessive heat generation. Fluids with low lubricity or low viscosity may require the maximum load and speed ratings to be derated to provide acceptable motor life and performance.

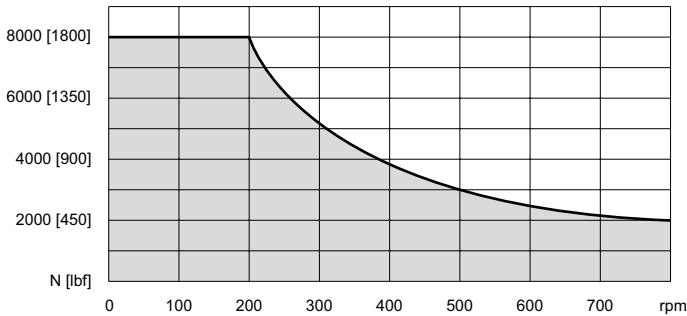

PERMISSIBLE SHAFT SEAL PRESSURE

The curve below represents allowable seal pressure at various speeds. Operation in the gray area results in maintaining the rated life of the shaft seal. Actual shaft seal pressure depends on motor configuration.

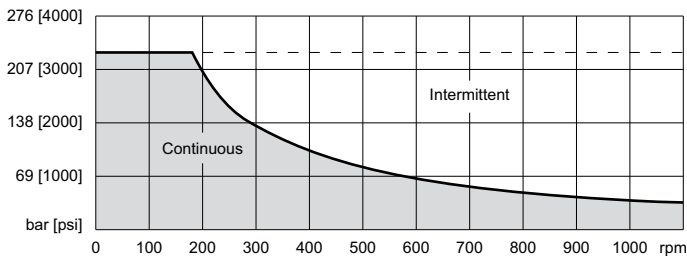

▶ With check valves and drain connection, the shaft seal pressure equals pressure in the drain line. With check valves and no drain connection, shaft seal pressure is identical to output pressure. No check valves and no drain connection, the shaft seal pressure is identical to the average value of input and output pressure.

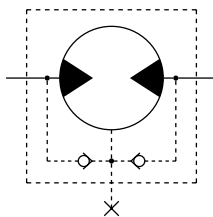

THRUST LOAD

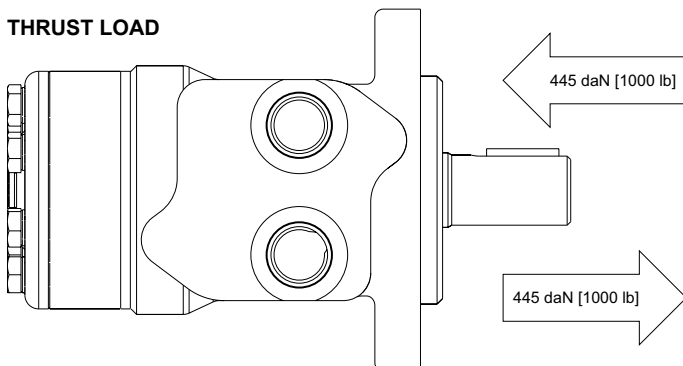

LENGTH & WEIGHT CHARTS

Dimension D is the overall motor length from the rear of the motor to the mounting flange surface and is referenced on detailed housing drawings listed on pages 35-38.

D	3mm Pilot	8mm Pilot	Weight
#	mm [in]	mm [in]	kg [lb]
025	133 [5.24]	128 [5.04]	6.3 [13.9]
032	134 [5.28]	129 [5.08]	6.4 [14.1]
040	136 [5.34]	131 [5.16]	6.5 [14.2]
050	136 [5.34]	131 [5.16]	6.5 [14.2]
060	137 [5.40]	132 [5.20]	6.5 [14.3]
080	139 [5.49]	134 [5.28]	6.6 [14.5]
100	142 [5.59]	137 [5.39]	6.7 [14.7]
125	146 [5.74]	141 [5.55]	6.8 [14.9]
160	150 [5.90]	145 [5.71]	6.9 [15.2]
200	155 [6.10]	150 [5.91]	7.1 [15.6]
250	162 [6.36]	157 [6.18]	7.3 [16.1]
315	170 [6.69]	165 [6.50]	7.6 [16.7]
400	181 [7.13]	176 [6.93]	7.9 [17.5]

Dimension E is the overall motor length from the rear of the motor to the mounting flange surface and is referenced on detailed housing drawings listed on pages 39.

E	3mm Pilot	8mm Pilot	Weight
#	mm [in]	mm [in]	kg [lb]
025	144 [5.67]	139 [5.47]	5.9 [13.0]
032	145 [5.71]	140 [5.51]	6.0 [13.2]
040	146 [5.75]	141 [5.55]	6.1 [13.4]
050	146 [5.75]	141 [5.55]	6.1 [13.4]
060	148 [5.83]	143 [5.63]	6.1 [13.4]
080	150 [5.91]	145 [5.71]	6.2 [13.6]
100	153 [6.02]	148 [5.83]	6.3 [13.9]
125	157 [6.18]	152 [5.98]	6.4 [14.1]
160	161 [6.33]	156 [6.14]	6.5 [14.3]
200	166 [6.54]	161 [6.34]	6.7 [14.7]
250	173 [6.81]	168 [6.61]	6.9 [15.2]
315	181 [7.13]	176 [6.93]	7.2 [15.8]
400	192 [7.56]	187 [7.36]	7.5 [16.5]

▶ The overall motor weights listed in each chart above were calculated using the heaviest of the housing options associated with that mounting flange to end of motor dimension. 155 & 156 series motor weights can vary ± 0.5 kg [1 lb] depending on model configurations such as housing, shaft, endcover, options etc.

SHAFTS

01 7/8" 13 Tooth Spline

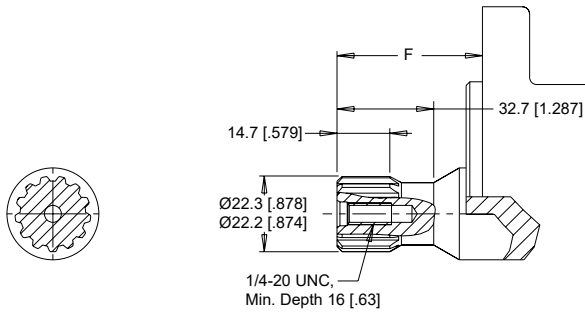

Max. Torque: 170 Nm [1500 lb-in]

02 1" 6B Spline, 1/4-20 Tap

04 1" 6B Spline, M8x1.25 Tap

F3 1" 6B Spline, M8x1.25 Tap

02, 04 - 6B Spline
SAE J499 Standard
F3 - 6B Spline
B.S. 2059 Standard

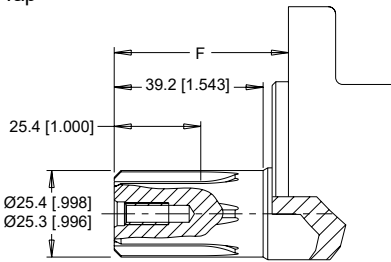
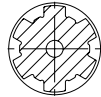

Max. Torque: 678 Nm [6000 lb-in]

05 1" - 9.5 [.375] Pinhole

53 1" - 10.3 [.406] Pinhole

66 1" - 8.0 [.315] Pinhole

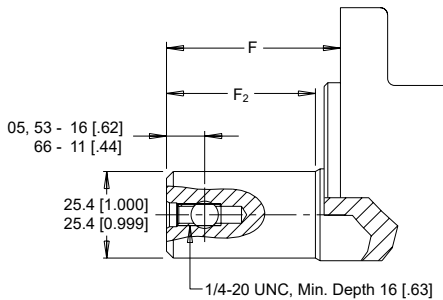
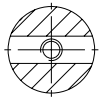

Max. Torque: 678 Nm [6000 lb-in]

10 1" Straight

15 1" Straight Extended

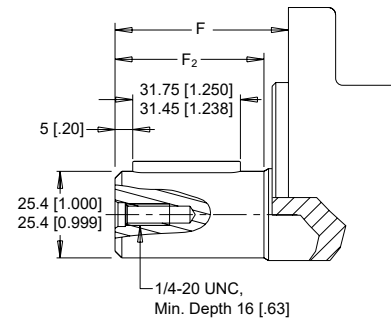
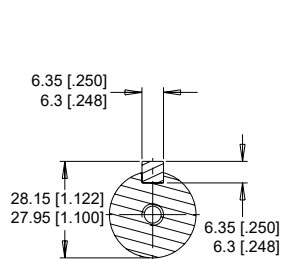

Max. Torque: 655 Nm [5800 lb-in]

12 25mm Straight

16 25mm Straight Extended

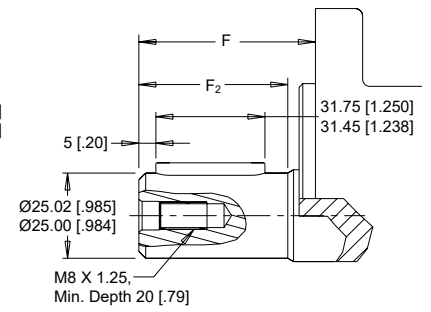
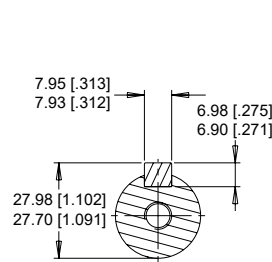

Max. Torque: 655 Nm [5800 lb-in]

B1 1" Straight, Woodruff Key

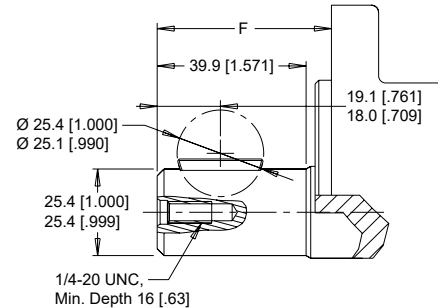
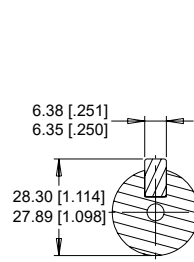

Max. Torque: 655 Nm [5800 lb-in]

MOUNTING / SHAFT LENGTH CHART

Dimension F is the overall distance from the motor mounting surface to the end of the shaft.

Additional shaft length information, if necessary, is noted as F₂ and does not increase or decrease the listed F dimensions in this chart. The overall shaft lengths are already factored into the overall distance from the mounting surface to the end of the shaft.

F	3mm Pilot	8mm Pilot	F ₂
#	mm [in]	mm [in]	mm [in]
01	43.3 [1.705]	48.3 [1.902]	N/A
02	45.3 [1.783]	50.3 [1.980]	N/A
04	45.3 [1.783]	50.3 [1.980]	N/A
05	45.3 [1.783]	50.3 [1.980]	39.2 [1.543]
10	45.3 [1.783]	50.3 [1.980]	39.2 [1.543]
12	50.3 [1.980]	55.3 [2.177]	44.2 [1.740]
15	62.1 [2.445]	67.1 [2.642]	56.0 [2.205]
16	62.6 [2.464]	67.6 [2.661]	56.5 [2.225]
53	45.3 [1.783]	50.3 [1.980]	39.2 [1.543]
66	50.3 [1.980]	55.3 [2.177]	44.2 [1.740]
B1	45.3 [1.783]	50.3 [1.980]	N/A

ORDERING INFORMATION

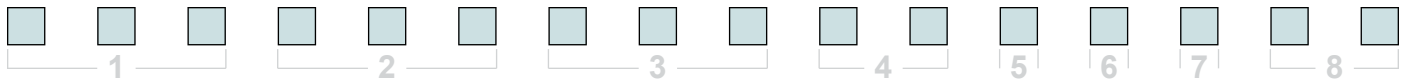

1. CHOOSE SERIES DESIGNATION

155 Standard Rotation	156 Reverse Rotation
------------------------------	-----------------------------

► The 155 & 156 series are bi-directional.

2. SELECT A DISPLACEMENT OPTION

025 25 cm ³ /rev [1.5 in ³ /rev]	125 125 cm ³ /rev [7.6 in ³ /rev]
032 32 cm ³ /rev [2.0 in ³ /rev]	160 154 cm ³ /rev [9.4 in ³ /rev]
040 40 cm ³ /rev [2.5 in ³ /rev]	200 190 cm ³ /rev [11.6 in ³ /rev]
050 50 cm ³ /rev [3.0 in ³ /rev]	250 240 cm ³ /rev [14.6 in ³ /rev]
060 59 cm ³ /rev [3.6 in ³ /rev]	315 303 cm ³ /rev [18.5 in ³ /rev]
080 78 cm ³ /rev [4.8 in ³ /rev]	400 388 cm ³ /rev [23.7 in ³ /rev]
100 96 cm ³ /rev [5.9 in ³ /rev]	

3. SELECT A MOUNT & PORT OPTION

A06 2-Hole, SAE A Mount, Aligned End Ports, 3/4-16 UNF
A08 2-Hole, SAE A Mount, Aligned End Ports, G 1/2
AP6 2-Hole, SAE A Mount, Aligned End Ports, 3/4-16 UNF (TP)
AP8 2-Hole, SAE A Mount, Aligned End Ports, G 1/2 (TP)
A10 2-Hole, SAE A Mount, Aligned Ports, 1/2-14 NPT
A11 2-Hole, SAE A Mount, Aligned Ports, 7/8-14 UNF
A12 2-Hole, SAE A Mount, Offset Ports, G 1/2
A13 2-Hole, SAE A Mount, Offset Manifold Ports, G 1/2
A17 2-Hole, SAE A Mount, Aligned Manifold Ports, 1/2" Drilled
A18 2-Hole, SAE A Mount, Aligned Ports, G 1/2
A19 2-Hole, SAE A Mount, Offset Ports, Valve Cavity 7/8-14 UNF
A30 4-Hole, Magneto Mount, Aligned Ports, 1/2-14 NPT
A31 4-Hole, Magneto Mount, Aligned Ports, 7/8-14 UNF
A32 4-Hole, Magneto Mount, Offset Ports, G 1/2
A37 4-Hole, Magneto Mount, Aligned Manifold Ports, 1/2" Drilled
A39 4-Hole, Magneto Mount, Offset Ports, Valve Cavity 7/8-14 UNF
A3D 4-Hole, Magneto Mount, Offset Manifold Ports, 7/8-14 UNF
A62 2-Hole, SAE A Mount, Offset Ports, G 1/2 (TP)
A63 2-Hole, SAE A Mount, Offset Manifold Ports, G 1/2 (TP)
A68 2-Hole, SAE A Mount, Aligned Ports, G 1/2 (TP)
A69 2-Hole, SAE A Mount, Offset Ports, 7/8-14 UNF (TP)
AC2 4-Hole, Magneto Mount, Offset Ports, G 1/2 (TP)
AC3 4-Hole, Magneto Mount, Offset Manifold Ports, G 1/2 (TP)
AC7 4-Hole, Magneto Mount, Aligned Manifold Ports, 1/2" Drilled (TP)

► (TP) - Tall pilot. Speed sensor option is not available on tall pilot housings.

3. SELECT A MOUNT & PORT OPTION

AC8 4-Hole, Magneto Mount, Aligned Ports, G 1/2 (TP)
F21 4-Hole, Square Mount, Aligned End Ports, 7/8-14 UNF
F26 4-Hole, Square Mount, Aligned End Ports, 3/4-16 UNF
F30 4-Hole, Square Mount, Aligned Ports, 1/2-14 NPT
F31 4-Hole, Square Mount, Aligned Ports, 7/8-14 UNF
F37 4-Hole, Square Mount, Aligned Manifold Ports, 1/2" Drilled
F38 4-Hole, Square Mount, Aligned Ports, G 1/2
G17 2-Hole, SAE A Mount, Aligned Manifold Ports, 1/2" Drilled
G24 4-Hole, Square Mount, Aligned End Ports, M22 x 1.5
G28 4-Hole, Square Mount, Aligned End Ports, G 1/2

4. SELECT A SHAFT OPTION

01 7/8" 13 Tooth Spline	15 1" Straight Extended
02 1" 6B Spline, 1/4-20 Tap	16 25mm Straight Extended
04 1" 6B Spline, M8x1.25 Tap	53 1" - 10.3 [.406] Pinhole
05 1" - 9.5 [.375] Pinhole	66 1" - 8.0 [.315] Pinhole
10 1" Straight	B1 1" Straight, Woodruff Key
12 25mm Straight	F3 1" 6B Spline, M8x1.25 Tap

► The 15 & 16 extended shafts are designed for use with one of the speed sensor options listed in STEP 7.

5. SELECT A PAINT OPTION

A Black
B Black, Unpainted Mounting Surface

6. SELECT A VALVE CAVITY / CARTRIDGE OPTION

A None	E 104 bar [1500 psi] Relief
B Valve Cavity Only	F 121 bar [1750 psi] Relief
C 69 bar [1000 psi] Relief	G 138 bar [2000 psi] Relief
D 86 bar [1250 psi] Relief	J 173 bar [2500 psi] Relief

► Valve cavity is only available on the A19, A39 & AC2 housings.

7. SELECT AN ADD-ON OPTION

A Standard
B Lock Nut
C Solid Hex Nut
W Speed Sensor, Dual, 4-Pin Male Weatherpack Connector
X Speed Sensor, Dual, 4-Pin M12 Male Connector
Y Speed Sensor, Single, 3-Pin Male Weatherpack Connector
Z Speed Sensor, Single, 4-Pin M12 Male Connector

8. SELECT A MISCELLANEOUS OPTION

AA None	DS Groove In Mounting Flange
AC Freeturning Rotor	FB No Check Valves Installed
BE Slinger Seal	

HOUSINGS

► Dimensions shown are without paint. Paint thickness can be up to 0.13 [.005].

2-HOLE, SAE A MOUNT, OFFSET MANIFOLD PORTS

A63 G 1/2

A6D 7/8-14 UNF

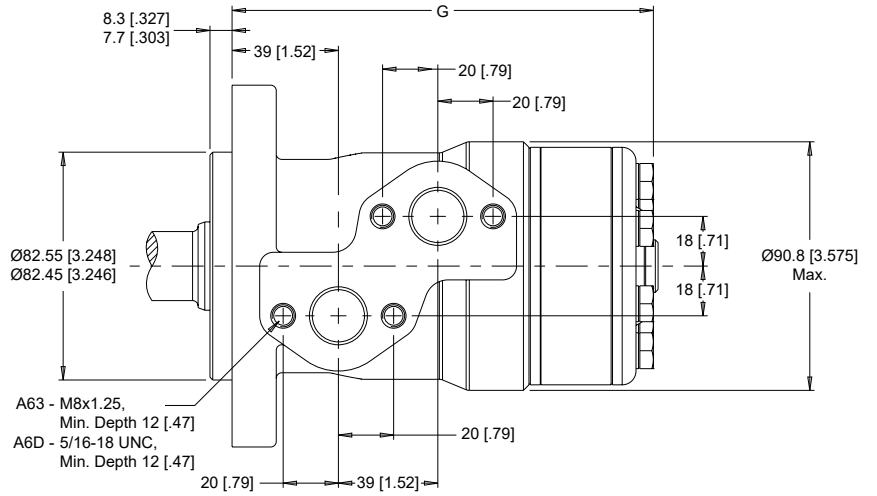
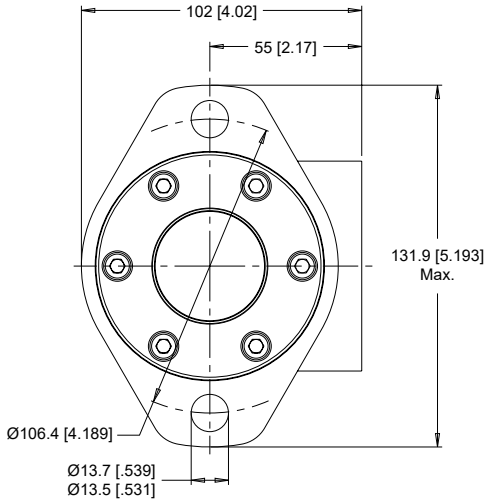

4-HOLE, WHEEL MOUNT, ALIGNED PORTS

W31 7/8-14 UNF

W38 G 1/2

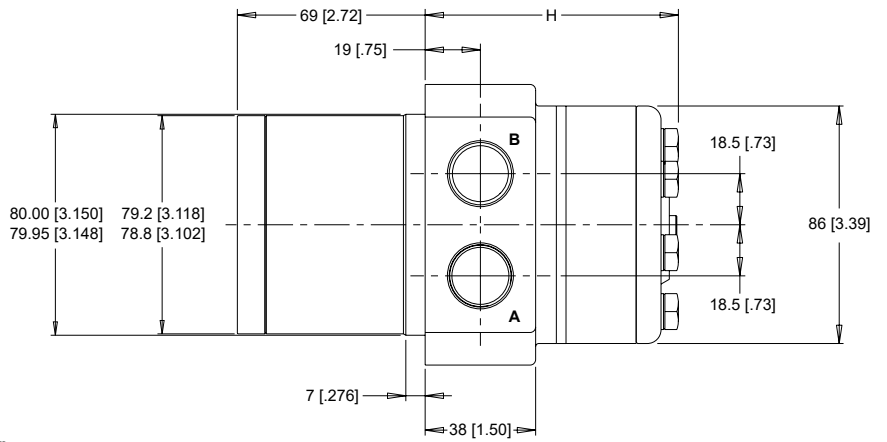
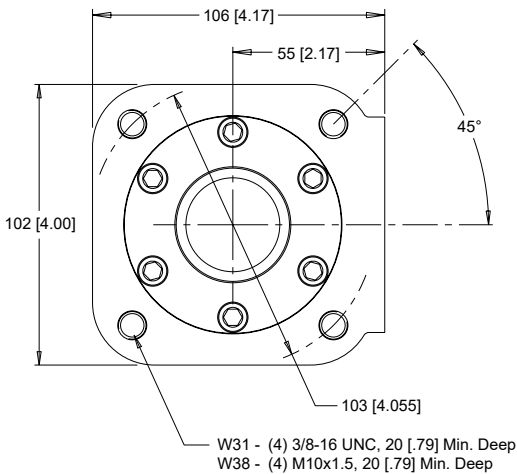

► Dimensions G & H are charted on page 44.

TECHNICAL INFORMATION

ALLOWABLE SHAFT LOAD / BEARING CURVE

The bearing curve represents allowable bearing loads based on ISO 281 bearing capacity for an L_{10} life of 2,000 hours at 100 rpm. Radial loads for speeds other than 100 rpm may be calculated using the multiplication factor table on page 7.

SAE A MOUNT

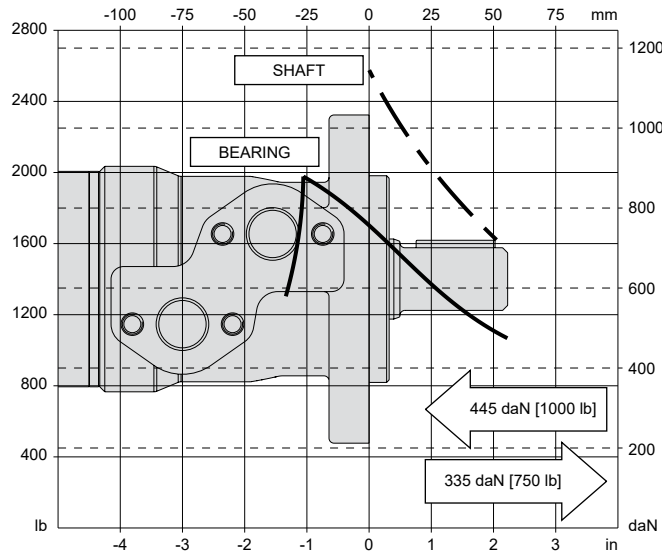

LENGTH & WEIGHT CHART

Dimension G is the overall motor length from the rear of the motor to the mounting flange surface.

G	Length	Weight
#	mm [in]	kg [lb]
025	133 [5.24]	6.0 [13.3]
032	134 [5.28]	6.1 [13.4]
040	136 [5.33]	6.1 [13.5]
050	136 [5.33]	6.1 [13.5]
060	137 [5.39]	6.2 [13.6]
080	139 [5.48]	6.2 [13.6]
100	142 [5.59]	6.3 [13.9]
125	146 [5.74]	6.4 [14.2]
160	150 [5.89]	6.6 [14.5]
200	155 [6.09]	6.7 [14.9]
250	161 [6.35]	7.0 [15.3]
315	170 [6.69]	7.2 [15.9]
400	181 [7.13]	7.6 [16.8]

WHEEL MOUNT

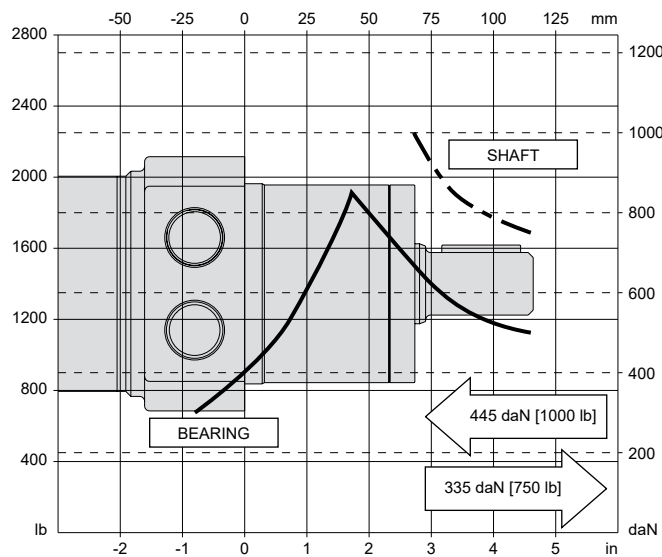

LENGTH & WEIGHT CHART

Dimension H is the overall motor length from the rear of the motor to the mounting flange surface.

H	Length	Weight
#	mm [in]	kg [lb]
025	72 [2.83]	6.4 [14.1]
032	73 [2.87]	6.5 [14.4]
040	75 [2.95]	6.6 [14.5]
050	75 [2.95]	6.6 [14.5]
060	76 [2.99]	6.7 [14.8]
080	78 [3.07]	6.8 [15.0]
100	81 [3.19]	6.9 [15.2]
125	85 [3.35]	7.0 [15.5]
160	89 [3.50]	7.1 [15.6]
200	94 [3.70]	7.2 [15.9]
250	100 [3.94]	7.4 [16.4]
315	109 [4.29]	7.7 [17.0]
400	120 [4.72]	8.1 [17.8]

SHAFTS

10 1" Straight, 1/4-20 Tap

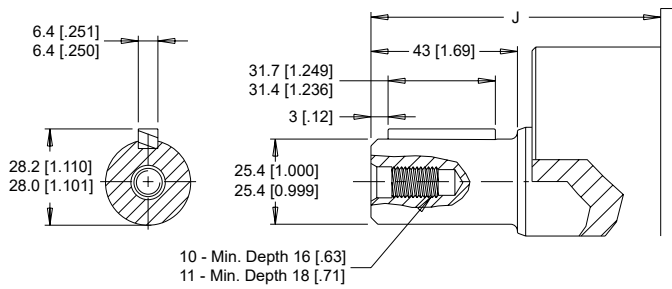

Max. Torque: 655 Nm [5800 lb-in]

11 1" Straight, M8x1.25 Tap

12 25mm Straight

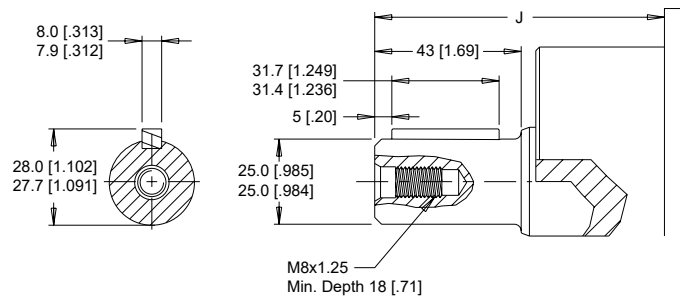

Max. Torque: 655 Nm [5800 lb-in]

13 1" Tapered

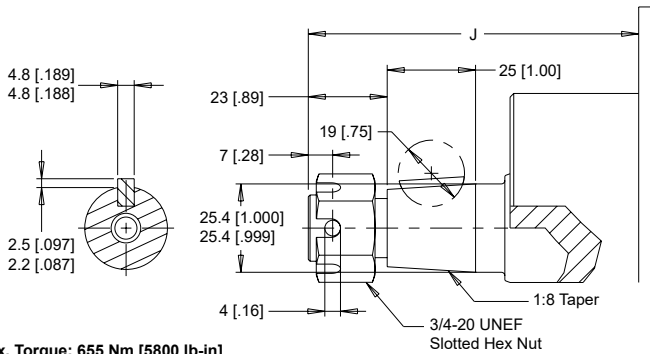

Max. Torque: 655 Nm [5800 lb-in]

F3 1" 6B Spline

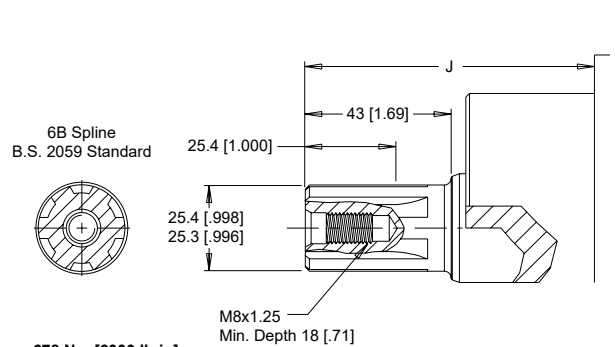

Max. Torque: 678 Nm [6000 lb-in]

N9 28.5mm Tapered

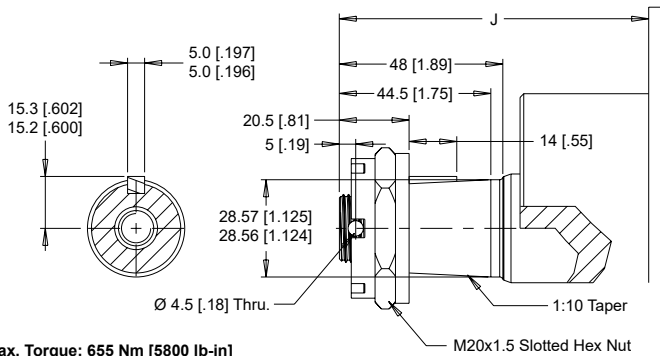

Max. Torque: 655 Nm [5800 lb-in]

MOUNTING / SHAFT LENGTH CHART

Dimension J is the overall distance from the motor mounting surface to the end of the shaft.

J #	SAE A Mounts mm [in]	Wheel Mounts mm [in]
10	55 [2.18]	116 [4.57]
11	55 [2.18]	116 [4.57]
12	55 [2.18]	116 [4.57]
13	66 [2.60]	127 [5.00]
F3	55 [2.18]	116 [4.57]
N9	58 [2.29]	119 [4.69]

ORDERING INFORMATION

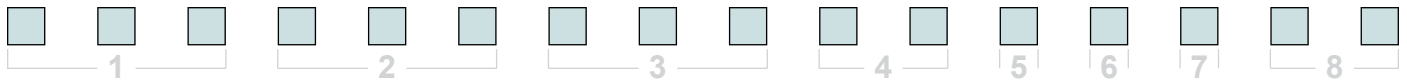

1. CHOOSE SERIES DESIGNATION

- 157** Clockwise Rotation
- 158** Counterclockwise Rotation

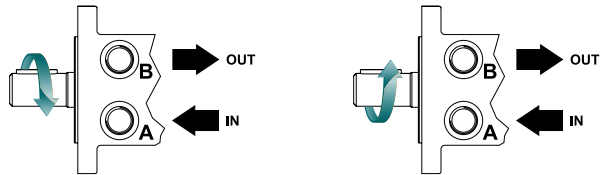

► The 157 & 158 series are bi-directional. Reversing the inlet hose will reverse shaft rotation.

2. SELECT A DISPLACEMENT OPTION

025	25 cm ³ /rev [1.5 in ³ /rev]	125	125 cm ³ /rev [7.6 in ³ /rev]
032	32 cm ³ /rev [2.0 in ³ /rev]	160	154 cm ³ /rev [9.4 in ³ /rev]
040	40 cm ³ /rev [2.5 in ³ /rev]	200	190 cm ³ /rev [11.6 in ³ /rev]
050	50 cm ³ /rev [3.0 in ³ /rev]	250	240 cm ³ /rev [14.6 in ³ /rev]
060	59 cm ³ /rev [3.6 in ³ /rev]	315	303 cm ³ /rev [18.5 in ³ /rev]
080	78 cm ³ /rev [4.8 in ³ /rev]	400	388 cm ³ /rev [23.7 in ³ /rev]
100	96 cm ³ /rev [5.9 in ³ /rev]		

3. SELECT A MOUNT & PORT OPTION

A63	2-Hole, SAE A Mount, Offset Manifold Ports, G 1/2 (TP)
A6D	2-Hole, SAE A Mount, Offset Manifold Ports, 7/8-14
W31	UNF 4-Hole, Wheel Mount, Aligned Ports, 7/8-14 UNF
W38	4-Hole, Wheel Mount, Aligned Ports, G 1/2

4. SELECT A SHAFT OPTION

10	1" Straight, 1/4-20 Tap	13	1" Tapered
11	1" Straight, M8x1.25 Tap	F3	1" 6B Spline
12	25mm Straight	N9	28.5mm Tapered

5. SELECT A PAINT OPTION

A	Black
B	Black, Unpainted Mounting Surface

6. SELECT A VALVE CAVITY / CARTRIDGE OPTION

A	None
----------	------

7. SELECT AN ADD-ON OPTION

A	Standard
----------	----------

8. SELECT A MISCELLANEOUS OPTION

AA	None
AC	Freeturning Rotor