

Impro
Fluidtek

Technical Information

Orbital Motors Type WM



TABLE OF CONTENTS

TECHNICAL INFORMATION

Operating Recommendations 4-5
 Motor Connections 5
 Product Testing (Understanding the Performance Charts) 6
 Allowable Bearing & Shaft Loads 7
 Vehicle Drive Calculations 8-9
 Induced Side Loading 10
 Hydraulic Equations 10
 Shaft Nut Dimensions & Torque Specifications 11

OPTIONAL MOTOR FEATURES

WM Product Line Introduction 12
 WM Displacement Performance Charts 13-14
 125 & 126 Series Housings 15
 125 & 126 Series Technical Information 16
 125 & 126 Series Shafts 16
 125 & 126 Series Ordering Information 17

OPERATING RECOMMENDATIONS

OIL TYPE

Hydraulic oils with anti-wear, anti-foam and demulsifiers are recommended for systems incorporating Impro Fluidtek motors. Straight oils can be used but may require VI (viscosity index) improvers depending on the operating temperature range of the system. Other water based and environmentally friendly oils may be used, but service life of the motor and other components in the system may be significantly shortened. Before using any type of fluid, consult the fluid requirements for all components in the system for compatibility. Testing under actual operating conditions is the only way to determine if acceptable service life will be achieved.

FLUID VISCOSITY & FILTRATION

Fluids with a viscosity between 20 - 43 cSt [100 - 200 S.U.S.] at operating temperature is recommended. Fluid temperature should also be maintained below 85°C [180° F]. It is also suggested that the type of pump and its operating specifications be taken into account when choosing a fluid for the system. Fluids with high viscosity can cause cavitation at the inlet side of the pump. Systems that operate over a wide range of temperatures may require viscosity improvers to provide acceptable fluid performance.

Impro Fluidtek recommends maintaining an oil cleanliness level of ISO 17-14 or better.

INSTALLATION & START-UP

When installing an Impro Fluidtek motor it is important that the mounting flange of the motor makes full contact with the mounting surface of the application. Mounting hardware of the appropriate grade and size must be used. Hubs, pulleys, sprockets and couplings must be properly aligned to avoid inducing excessive thrust or radial loads. Although the output device must fit the shaft snug, a hammer should never be used to install any type of output device onto the shaft. The port plugs should only be removed from the motor when the system connections are ready to be made. To avoid contamination, remove all matter from around the ports of the motor and the threads of the fittings. Once all system connections are made, it is recommended that the motor be run-in for 15-30 minutes at no load and half speed to remove air from the hydraulic system.

MOTOR PROTECTION

Over-pressurization of a motor is one of the primary causes of motor failure. To prevent these situations, it is necessary to provide adequate relief protection for a motor based on the pressure ratings for that particular model. For systems that may experience overrunning conditions, special precautions must be taken. In an overrunning condition, the motor functions as a pump and attempts to convert kinetic energy into hydraulic energy. Unless the system is properly

configured for this condition, damage to the motor or system can occur. To protect against this condition a counterbalance valve or relief cartridge must be incorporated into the circuit to reduce the risk of over-pressurization. If a relief cartridge is used, it must be installed upline of the motor, if not in the motor, to relieve the pressure created by the over-running motor. To provide proper motor protection for an over-running load application, the pressure setting of the pressure relief valve must not exceed the intermittent rating of the motor.

HYDRAULIC MOTOR SAFETY PRECAUTION

A hydraulic motor must not be used to hold a suspended load. Due to the necessary internal tolerances, all hydraulic motors will experience some degree of creep when a load induced torque is applied to a motor at rest. All applications that require a load to be held must use some form of mechanical brake designed for that purpose.

MOTOR/BRAKE PRECAUTION

Caution! - Impro Fluidtek motor/brakes are intended to operate as static or parking brakes. System circuitry must be designed to bring the load to a stop before applying the brake.

Caution! - Because it is possible for some large displacement motors to overpower the brake, it is critical that the maximum system pressure be limited for these applications. Failure to do so could cause serious injury or death. When choosing a motor/brake for an application, consult the performance chart for the series and displacement chosen for the application to verify that the maximum operating pressure of the system will not allow the motor to produce more torque than the maximum rating of the brake. Also, it is vital that the system relief be set low enough to insure that the motor is not able to overpower the brake.

To ensure proper operation of the brake, a separate case drain back to tank must be used. Use of the internal drain option is not recommended due to the possibility of return line pressure spikes. A simple schematic of a system utilizing a motor/brake is shown on page 4. Although maximum brake release pressure may be used for an application, a 34 bar [500 psi] pressure reducing valve is recommended to promote maximum life for the brake release piston seals. However, if a pressure reducing valve is used in a system which has case drain back pressure, the pressure reducing valve should be set to 34 bar [500 psi] over the expected case pressure to ensure full brake release. To achieve proper brake release operation, it is necessary to bleed out any trapped air and fill brake release cavity and hoses before all connections are tightened. To facilitate this operation, all motor/brakes feature two release ports. One or both of these ports may be used to release the brake in the

OPERATING RECOMMENDATIONS & MOTOR CONNECTIONS

MOTOR/BRAKE PRECAUTION (continued)

unit. Motor/brakes should be configured so that the release ports are near the top of the unit in the installed position.

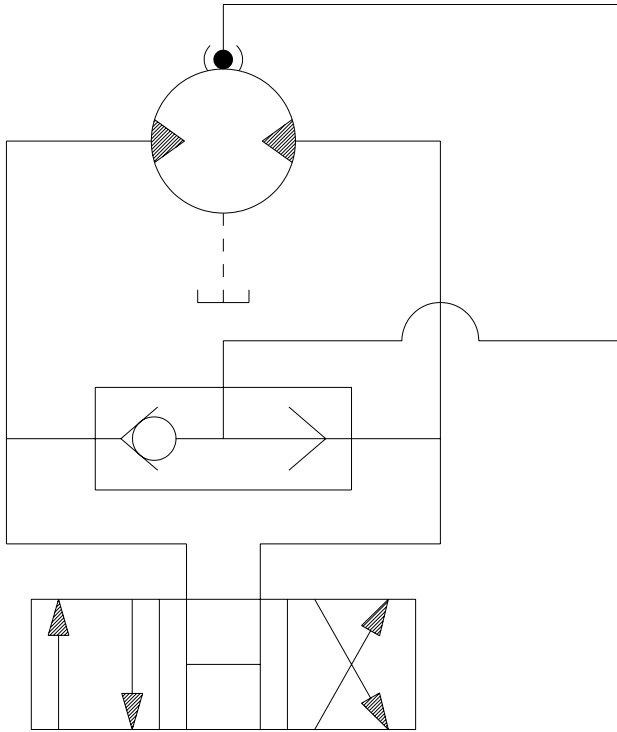

TYPICAL MOTOR/BRAKE SCHEMATIC

Once all system connections are made, one release port must be opened to atmosphere and the brake release line carefully charged with fluid until all air is removed from the line and motor/brake release cavity. When this has been accomplished the port plug or secondary release line must be reinstalled. In the event of a pump or battery failure, an external pressure source may be connected to the brake release port to release the brake, allowing the machine to be moved.

► NOTE: It is vital that all operating recommendations be followed. Failure to do so could result in injury or death.

MOTOR CIRCUITS

There are two common types of circuits used for connecting multiple numbers of motors – series connection and parallel connection.

SERIES CONNECTION

When motors are connected in series, the outlet of one motor is connected to the inlet of the next motor. This allows the full pump flow to go through each motor and provide maximum speed. Pressure and torque are distributed between the motors based on the load each motor is subjected to. The maximum system pressure must be no greater than the maximum inlet pressure of the first motor. The allowable back pressure rating for a motor must also be considered. In some series circuits the motors must have an external case drain connected. A series connection is desirable when it is important for all the motors to run the same speed such as on a long line conveyor.

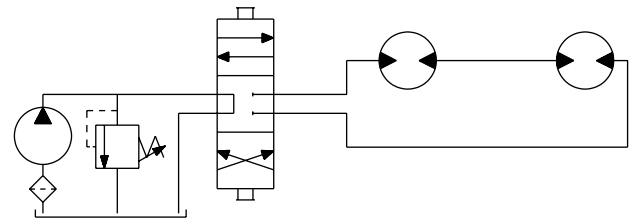

SERIES CIRCUIT

PARALLEL CONNECTION

In a parallel connection all of the motor inlets are connected. This makes the maximum system pressure available to each motor allowing each motor to produce full torque at that pressure. The pump flow is split between the individual motors according to their loads and displacements. If one motor has no load, the oil will take the path of least resistance and all the flow will go to that one motor. The others will not turn. If this condition can occur, a flow divider is recommended to distribute the oil and act as a differential.

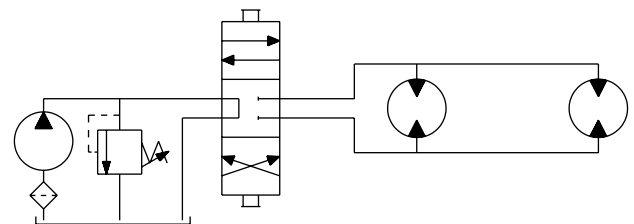

PARALLEL CIRCUIT

► NOTE: The motor circuits shown above are for illustration purposes only. Components and circuitry for actual applications may vary greatly and should be chosen based on the application.

PRODUCT TESTING

Performance testing is the critical measure of a motor's ability to convert flow and pressure into speed and torque. All product testing is conducted using an Impro Fluidtek state of the art test facility. This facility utilizes fully automated test equipment and custom designed software to provide accurate, reliable test data. Test routines are standardized, including test stand calibration and stabilization of fluid temperature and viscosity, to provide consistent data. The example below provides an explanation of the values pertaining to each heading on the performance chart.

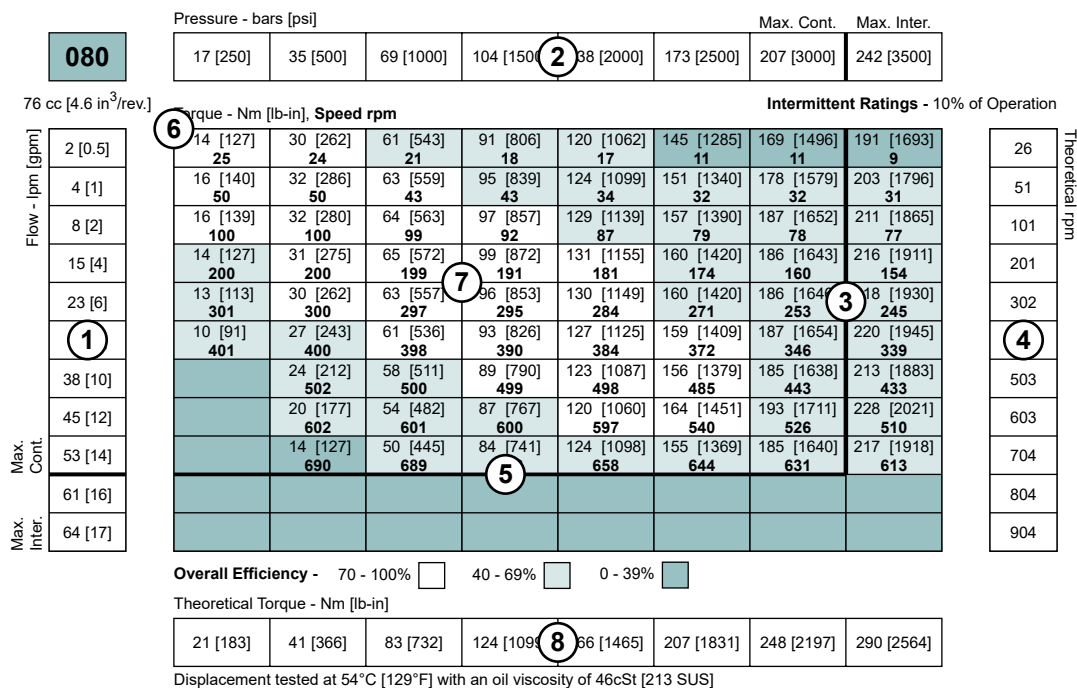

- Flow represents the amount of fluid passing through the motor during each minute of the test.
- Pressure refers to the measured pressure differential between the inlet and return ports of the motor during the test.
- The maximum continuous pressure rating and maximum intermittent pressure rating of the motor are separated by the dark lines on the chart.
- Theoretical RPM represents the RPM that the motor would produce if it were 100% volumetrically efficient. Measured RPM divided by the theoretical RPM give the actual volumetric efficiency of the motor.
- The maximum continuous flow rating and maximum intermittent flow rating of the motor are separated by the dark line on the chart.
- Performance numbers represent the actual torque and speed generated by the motor based on the corresponding input pressure and flow. The numbers on the top row indicate torque as measured in Nm [lb-in], while the bottom number represents the speed of the output shaft.
- Areas within the white shading represent maximum motor efficiencies.
- Theoretical Torque represents the torque that the motor would produce if it were 100% mechanically efficient. Actual torque divided by the theoretical torque gives the actual mechanical efficiency of the motor.

ALLOWABLE BEARING & SHAFT LOADING

This catalog provides curves showing allowable radial loads at points along the longitudinal axis of the motor. They are dimensioned from the mounting flange. Two capacity curves for the shaft and bearings are shown. A vertical line through the centerline of the load drawn to intersect the x-axis intersects the curves at the load capacity of the shaft and of the bearing.

In the example below the maximum radial load bearing rating is between the internal roller bearings illustrated with a solid line. The allowable shaft rating is shown with a dotted line.

The bearing curves for each model are based on laboratory analysis and testing results constructed at Impro Fluidtek. The shaft loading is based on a 3:1 safety factor and 330 Kpsi tensile strength. The allowable load is the lower of the curves at a given point. For instance, one inch in front of the mounting flange the bearing capacity is lower than the shaft capacity. In this case, the bearing is the limiting load. The motor user needs to determine which series of motor to use based on their application knowledge.

ISO 281 RATINGS VS. MANUFACTURERS RATINGS

Published bearing curves can come from more than one type of analysis. The ISO 281 bearing rating is an international standard for the dynamic load rating of roller bearings. The rating is for a set load at a speed of 33 1/3 RPM for 500 hours (1 million revolutions). The standard was established to allow consistent comparisons of similar bearings between manufacturers. The ISO 281 bearing ratings are based solely on the physical characteristics of the bearings, removing any manufacturers specific safety factors or empirical data that influences the ratings.

Manufacturers' ratings are adjusted by diverse and systematic laboratory investigations, checked constantly with feedback from practical experience. Factors taken into account that affect bearing life are material, lubrication, cleanliness of the lubrication, speed, temperature, magnitude of the load and the bearing type.

The operating life of a bearing is the actual life achieved by the bearing and can be significantly different from the calculated life. Comparison with similar applications is the most accurate method for bearing life estimations.

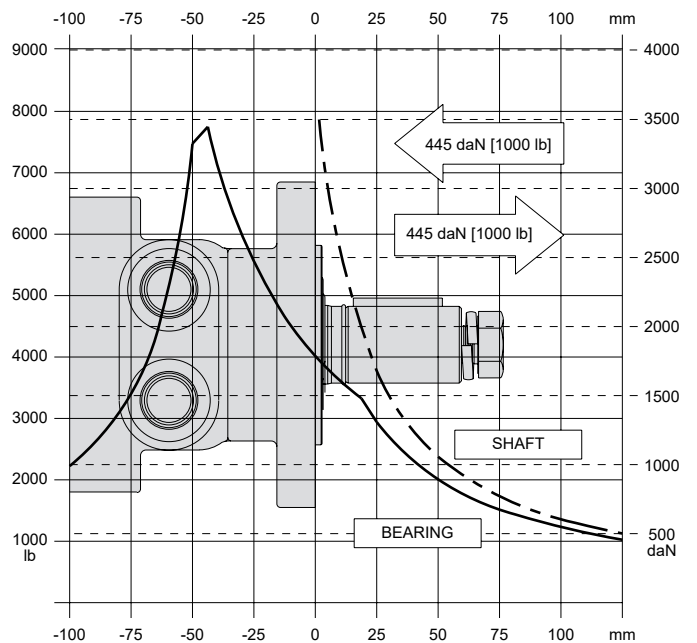

EXAMPLE LOAD RATING FOR MECHANICALLY RETAINED NEEDLE ROLLER BEARINGS

Bearing Life $L_{10} = (C/P)^p [10^6 \text{ revolutions}]$

L_{10} = nominal rating life

C = dynamic load rating

P = equivalent dynamic load

Life Exponent $P = 10/3$ for needle bearings

BEARING LOAD MULTIPLICATION FACTOR TABLE			
RPM	FACTOR	RPM	FACTOR
50	1.23	500	0.62
100	1.00	600	0.58
200	0.81	700	0.56
300	0.72	800	0.50
400	0.66		

VEHICLE DRIVE CALCULATIONS

When selecting a wheel drive motor for a mobile vehicle, a number of factors concerning the vehicle must be taken into consideration to determine the required maximum motor RPM, the maximum torque required and the maximum load each motor must support. The following sections contain the necessary equations to determine this criteria. An example is provided to illustrate the process.

Sample application (vehicle design criteria)

vehicle description..... 4 wheel vehicle
 vehicle drive.....2 wheel drive
 GVW1,500lbs.
 weight over each drive wheel 425 lbs.
 rolling radius of tires 16 in.
 desired acceleration0-5 mph in 10 sec.
 top speed..... 5 mph
 gradability.....20%
 worst working surface..... poor asphalt

To determine maximum motor speed

$$RPM = \frac{2.65 \times KPH \times G}{rm} \quad RPM = \frac{168 \times MPH \times G}{ri}$$

Where:

MPH = max. vehicle speed (miles/hr)
 KPH = max. vehicle speed (kilometers/hr)
 ri = rolling radius of tire (inches)
 G = gear reduction ratio (if none, G = 1)
 rm = rolling radius of tire (meters)

Example $RPM = \frac{168 \times 5 \times 1}{16} = 52.5$

To determine maximum torque requirement of motor

To choose a motor(s) capable of producing enough torque to propel the vehicle, it is necessary to determine the Total Tractive Effort (TE) requirement for the vehicle. To determine the total tractive effort, the following equation must be used:

$$TE = RR + GR + FA + DP \text{ (lbs or N)}$$

Where:

TE = Total tractive effort
 RR = Force necessary to overcome rolling resistance
 GR = Force required to climb a grade
 FA = Force required to accelerate
 DP = Drawbar pull required

The components for this equation may be determined using the following steps:

Step One: Determine Rolling Resistance

Rolling Resistance (RR) is the force necessary to propel a vehicle over a particular surface. It is recommended that the worst possible surface type to be encountered by the vehicle be factored into the equation.

$$RR = \frac{GVW}{1000} \times R \text{ (lb or N)}$$

Where:

GVW = gross (loaded) vehicle weight (lb or kg)
 R = surface friction (value from Table 1)

Example $RR = \frac{1500}{1000} \times 22 \text{ lbs} = 33 \text{ lbs}$

Table 1

Rolling Resistance	
Concrete (excellent).....	10
Concrete (good).....	15
Concrete (poor).....	20
Asphalt (good).....	12
Asphalt (fair).....	17
Asphalt (poor).....	22
Macadam (good).....	15
Macadam (fair).....	22
Macadam (poor).....	37
Cobbles (ordinary).....	55
Cobbles (poor).....	37
Snow (2 inch).....	25
Snow (4 inch).....	37
Dirt (smooth).....	25
Dirt (sandy).....	37
Mud.....	37 to 150
Sand (soft).....	60 to 150
Sand (dune).....	160 to 300

Step Two: Determine Grade Resistance

Grade Resistance (GR) is the amount of force necessary to move a vehicle up a hill or "grade." This calculation must be made using the maximum grade the vehicle will be expected to climb in normal operation.

To convert incline degrees to % Grade:

$$\% \text{ Grade} = [\tan \text{ of angle (degrees)}] \times 100$$

$$GR = \frac{\% \text{ Grade}}{100} \times GVW \text{ (lb or N)}$$

Example $GR = \frac{20}{100} \times 1500 \text{ lbs} = 300 \text{ lbs}$

VEHICLE DRIVE CALCULATIONS

Step Three: Determine Acceleration Force

Acceleration Force (FA) is the force necessary to accelerate from a stop to maximum speed in a desired time.

$$FA = \frac{MPH \times GVW \text{ (lb)}}{22 \times t} \qquad FA = \frac{KPH \times GVW \text{ (N)}}{35.32 \times t}$$

Where:

t = time to maximum speed (seconds)

Example $FA = \frac{5 \times 1500 \text{ lbs}}{22 \times 10} = 34 \text{ lbs}$

Step Four: Determine Drawbar Pull

Drawbar Pull (DP) is the additional force, if any, the vehicle will be required to generate if it is to be used to tow other equipment. If additional towing capacity is required for the equipment, repeat steps one through three for the towable equipment and sum the totals to determine DP.

Step Five: Determine Total Tractive Effort

The Tractive Effort (TE) is the sum of the forces calculated in steps one through three above. On low speed vehicles, wind resistance can typically be neglected. However, friction in drive components may warrant the addition of 10% to the total tractive effort to insure acceptable vehicle performance.

$$TE = RR + GR + FA + DP \text{ (lb or N)}$$

Example $TE = 33 + 300 + 34 + 0 \text{ (lbs)} = 367 \text{ lbs}$

Step Six: Determine Motor Torque

The Motor Torque (T) required per motor is the Total Tractive Effort divided by the number of motors used on the machine. Gear reduction is also factored into account in this equation.

$$T = \frac{TE \times ri}{M \times G} \text{ lb-in per motor} \qquad T = \frac{TE \times rm}{M \times G} \text{ Nm per motor}$$

Where:

M = number of driving motors

Example $T = \frac{367 \times 16}{2 \times 1} \text{ lb-in/motor} = 2936 \text{ lb-in}$

Step Seven: Determine Wheel Slip

To verify that the vehicle will perform as designed in regards to tractive effort and acceleration, it is necessary to calculate wheel slip (TS) for the vehicle. In special cases, wheel slip may actually be desirable to prevent hydraulic system overheating and component breakage should the vehicle become stalled.

$$TS = \frac{W \times f \times ri}{G} \qquad TS = \frac{W \times f \times rm}{G}$$

(lb-in per motor) (N-m per motor)

Where:

f = coefficient of friction (see table 2)

W = loaded vehicle weight over driven wheel (lb or N)

Example $TS = \frac{425 \times .06 \times 16}{1} \text{ lb-in/motor} = 4080 \text{ lbs}$

Table 2

Coefficient of friction (f)	
Steel on steel.....	0.3
Rubber tire on dirt.....	0.5
Rubber tire on a hard surface	0.6 - 0.8
Rubber tire on cement.....	0.7

To determine radial load capacity requirement of motor

When a motor used to drive a vehicle has the wheel or hub attached directly to the motor shaft, it is critical that the radial load capabilities of the motor are sufficient to support the vehicle. After calculating the Total Radial Load (RL) acting on the motors, the result must be compared to the bearing/shaft load charts for the chosen motor to determine if the motor will provide acceptable load capacity and life.

$$RL = \sqrt{W^2 + \left(\frac{T}{ri}\right)^2} \text{ lb} \qquad RL = \sqrt{W^2 + \left(\frac{T}{rm}\right)^2} \text{ kg}$$

Example $RL = \sqrt{425^2 + \left(\frac{2936}{16}\right)^2} = 463 \text{ lbs}$

Once the maximum motor RPM, maximum torque requirement, and the maximum load each motor must support have been determined, these figures may then be compared to the motor performance charts and to the bearing load curves to choose a series and displacement to fulfill the motor requirements for the application.

INDUCED SIDE LOAD

In many cases, pulleys or sprockets may be used to transmit the torque produced by the motor. Use of these components will create a torque induced side load on the motor shaft and bearings. It is important that this load be taken into consideration when choosing a motor with sufficient bearing and shaft capacity for the application.

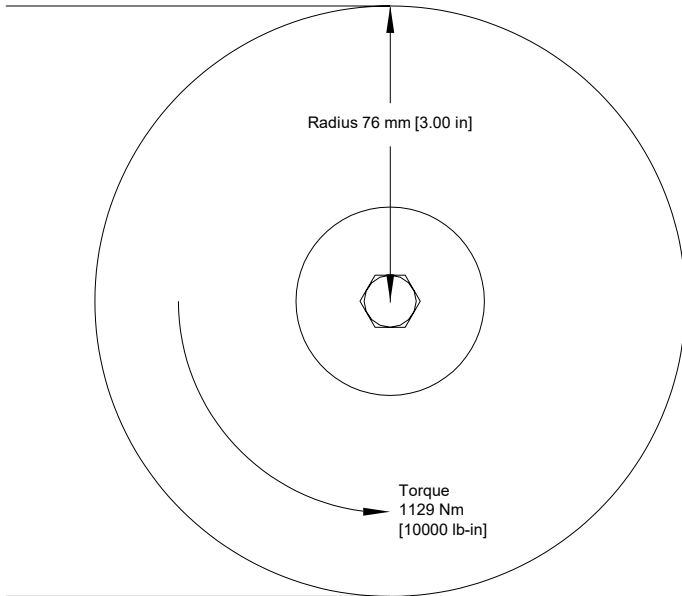

To determine the side load, the motor torque and pulley or sprocket radius must be known. Side load may be calculated using the formula below. The distance from the pulley/sprocket centerline to the mounting flange of the motor must also be determined. These two figures may then be compared to the bearing and shaft load curve of the desired motor to determine if the side load falls within acceptable load ranges.

$$\text{Side Load} = \frac{\text{Torque}}{\text{Radius}}$$

$$\text{Side Load} = 14855 \text{ N [3333 lbs]}$$

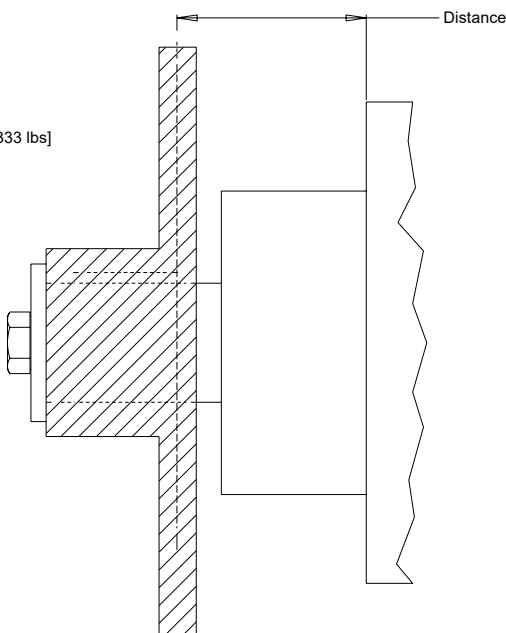

HYDRAULIC EQUATIONS

Multiplication Factor	Abbrev.	Prefix
10 ¹²	T	tera
10 ⁹	G	giga
10 ⁶	M	mega
10 ³	K	kilo
10 ²	h	hecto
10 ¹	da	deka
10 ⁻¹	d	deci
10 ⁻²	c	centi
10 ⁻³	m	milli
10 ⁻⁶	u	micro
10 ⁻⁹	n	nano
10 ⁻¹²	p	pico
10 ⁻¹⁵	f	femto
10 ⁻¹⁸	a	atto

Theo. Speed (RPM) =

$$\frac{1000 \times \text{LPM}}{\text{Displacement (cm}^3\text{/rev)}} \quad \text{or} \quad \frac{231 \times \text{GPM}}{\text{Displacement (in}^3\text{/rev)}}$$

Theo. Torque (lb-in) =

$$\frac{\text{Bar} \times \text{Disp. (cm}^3\text{/rev)}}{20 \pi} \quad \text{or} \quad \frac{\text{PSI} \times \text{Displacement (in}^3\text{/rev)}}{6.28}$$

Power In (HP) =

$$\frac{\text{Bar} \times \text{LPM}}{600} \quad \text{or} \quad \frac{\text{PSI} \times \text{GPM}}{1714}$$

Power Out (HP) =

$$\frac{\text{Torque (Nm)} \times \text{RPM}}{9543} \quad \text{or} \quad \frac{\text{Torque (lb-in)} \times \text{RPM}}{63024}$$

SHAFT NUT INFORMATION

35MM TAPERED SHAFTS
M24 x 1.5 Thread

A Slotted Nut

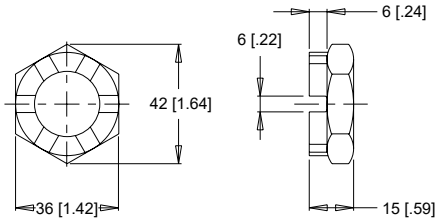

Torque Specifications: 32.5 daNm [240 ft.lb.]

PRECAUTION

The tightening torques listed with each nut should only be used as a guideline. Hubs may require higher or lower tightening torque depending on the material. Consult the hub manufacturer to obtain recommended tightening torque. To maximize torque transfer from the shaft to the hub, and to minimize the potential for shaft breakage, a hub with sufficient thickness must fully engage the taper length of the shaft.

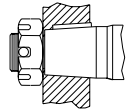

incorrect

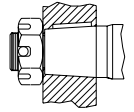

correct

1" TAPERED SHAFTS
3/4-28 Thread

A Slotted Nut

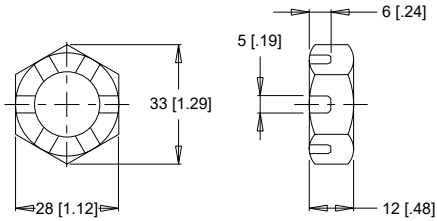

Torque Specifications: 20 - 23 daNm [150 - 170 ft.lb.]

B Lock Nut

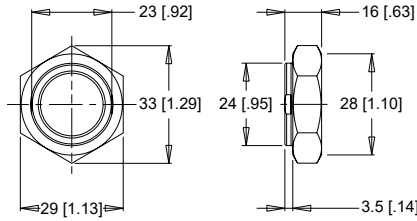

Torque Specifications: 24 - 27 daNm [180 - 200 ft.lb.]

C Solid Nut

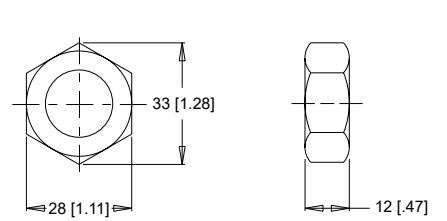

Torque Specifications: 20 - 23 daNm [150 - 170 ft.lb.]

1-1/4" TAPERED SHAFTS
1-20 Thread

A Slotted Nut

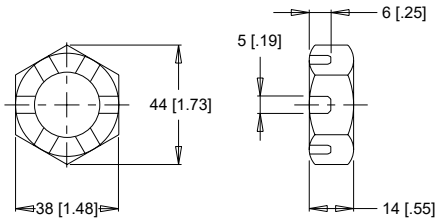

Torque Specifications: 38 daNm [280 ft.lb.] Max.

B Lock Nut

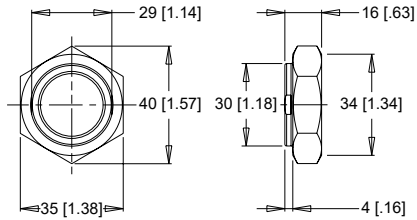

Torque Specifications: 33 - 42 daNm [240 - 310 ft.lb.]

C Solid Nut

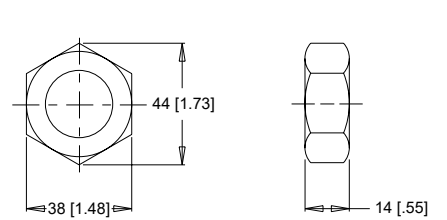

Torque Specifications: 38 daNm [280 ft.lb.] Max.

1-3/8" & 1-1/2" TAPERED SHAFTS
1 1/8-18 Thread

A Slotted Nut

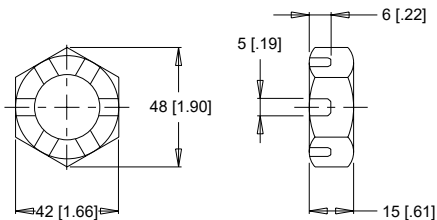

Torque Specifications: 41 - 54 daNm [300 - 400 ft.lb.]

B Lock Nut

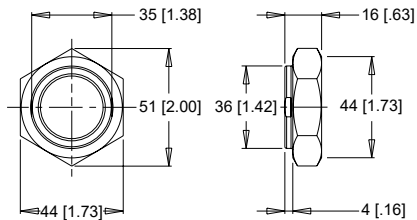

Torque Specifications: 34 - 48 daNm [250 - 350 ft.lb.]

C Solid Nut

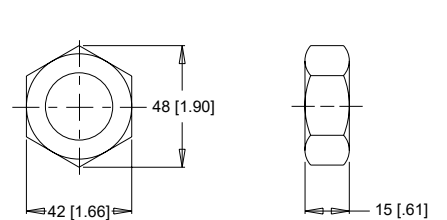

Torque Specifications: 41 - 54 daNm [300 - 400 ft.lb.]

WM (125/126 Series)

Light Duty Hydraulic Motor

OVERVIEW

The WM product line with spool valve design is an economical motor with enhanced rotor technology. Intended for light-duty applications, the WM series offers many advantages such as compact size, high speed, medium torque and extreme low weight. The WM series motors are used primarily in the mobile, industrial and agricultural markets.

FEATURES / BENEFITS

- Built-in check valves offer versatility and increased seal life.
- Bolt-on mounting flange relates to easy serviceability.
- Spool valve design gives superior performance and smooth operation over a wide speed and torque range.
- Enhanced rotor design provides smooth performance, compact volume and low weight.

TYPICAL APPLICATIONS

agriculture equipment, conveyors, carwashes, sweepers, food processing, grain augers, spreaders, feed rollers, augers, brush drives and more

SERIES DESCRIPTIONS

125/126 - Hydraulic Mini Motor
Standard

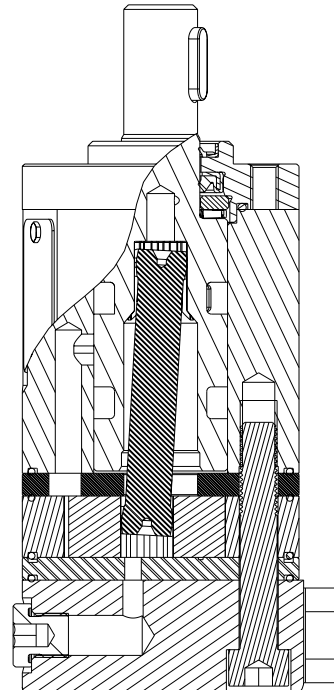

SPECIFICATIONS

CODE	Displacement cm ³ [in ³ /rev]	Max. Speed rpm		Max. Flow lpm [gpm]		Max. Torque Nm [lb-in]		Max. Pressure bar [psi]		
		cont.	inter.	cont.	inter.	cont.	inter.	cont.	inter.	peak
008	8.4 [0.5]	1864	2293	16 [4]	20 [5]	11 [97]	14 [124]	100 [1450]	140 [2030]	200 [2900]
012	13.1 [0.8]	1521	1871	20 [5]	25 [7]	17 [150]	22 [195]	100 [1450]	140 [2030]	200 [2900]
020	20.1 [1.2]	989	1229	20 [5]	25 [7]	26 [230]	34 [301]	100 [1450]	140 [2030]	200 [2900]
032	31.8 [1.9]	622	767	20 [5]	25 [7]	40 [354]	55 [487]	100 [1450]	140 [2030]	160 [2320]
040	40.2 [2.5]	495	620	20 [5]	25 [7]	49 [434]	64 [566]	100 [1450]	140 [2030]	160 [2320]
050	50.3 [3.0]	397	487	20 [5]	25 [7]	59 [531]	81 [708]	100 [1450]	140 [2030]	160 [2320]

► Performance data is typical. Performance of production units varies slightly from one motor to another. See page 9 for additional information on product testing. Running at intermittent ratings should not exceed 10% of every minute of operation.

DISPLACEMENT PERFORMANCE

► Performance data is typical. Performance of production units varies slightly from one motor to another. See page 6 for additional information on product testing.

008		Pressure - bar [psi]			Max. Cont.		Max. Inter.		
		30 [435]	50 [725]	70 [1015]	100 [1450]	120 [1740]	140 [2030]		
8 cm ³ [0.5 in ³] / rev									
Max. Max. Flow - lpm [gpm]		Torque - Nm [lb-in], Speed rpm						Intermittent Ratings - 10% of Operation	Theoretical rpm
		2 [0.5]	3 [25] 226	5 [44] 219	7 [62] 196	10 [89] 166	11 [97] 141	14 [124] 117	
Max. Max. Inter. Cont.		4 [1]	3 [25] 476	5 [44] 455	7 [62] 435	10 [89] 402	12 [106] 384	12 [106] 351	474
		8 [2]		5 [44] 915	7 [62] 893	10 [89] 850	12 [106] 816	14 [124] 778	949
Max. Max. Inter. Cont.		12 [3]		5 [41] 1390	7 [62] 1366	11 [97] 1328	12 [106] 1292	14 [124] 1268	1423
		16 [4]		4 [35] 1864	7 [58] 1847	10 [89] 1815	12 [106] 1792	13 [115] 1771	1898
Max. Max. Inter. Cont.		20 [5]		4 [35] 2293	6 [53] 2277	9 [80] 2272	12 [106] 2245	12 [106] 2190	2372
		Rotor Width		Theoretical Torque - Nm [lb-in]		Overall Efficiency - 70 - 100% <input type="checkbox"/> 40 - 69% <input type="checkbox"/> 0 - 39% <input checked="" type="checkbox"/>			
3.3 [130]		4 [36]		7 [59]		9 [83]		13 [119]	
mm [in]		Displacement tested at 45°C [113°F] with an oil viscosity of 46cSt [213 SUS]							

012		Pressure - bar [psi]			Max. Cont.		Max. Inter.		
		30 [435]	50 [725]	70 [1015]	100 [1450]	120 [1740]	140 [2030]		
13 cm ³ [0.8 in ³] / rev									
Max. Max. Flow - lpm [gpm]		Torque - Nm [lb-in], Speed rpm						Intermittent Ratings - 10% of Operation	Theoretical rpm
		3 [0.8]	5 [44] 220	8 [71] 212	11 [97] 195	16 [142] 176			
Max. Max. Inter. Cont.		5 [1.3]	6 [53] 367	9 [80] 362	12 [106] 351	17 [150] 320	19 [168] 304		383
		10 [2.6]	5 [44] 757	9 [80] 748	11 [97] 728	16 [142] 703	19 [168] 659	22 [195] 609	766
Max. Max. Inter. Cont.		15 [4.0]	4 [35] 1134	8 [71] 1124	11 [97] 1106	16 [142] 1072	18 [159] 1049	21 [186] 1026	1149
		20 [5.3]	3 [27] 1521	6 [53] 1511	10 [89] 1498	14 [124] 1480	17 [150] 1449	21 [186] 1413	1533
Max. Max. Inter. Cont.		25 [6.6]		5 [44] 1871	9 [80] 1858	13 [115] 1850	17 [150] 1840	19 [168] 1793	1916
		Rotor Width		Theoretical Torque - Nm [lb-in]		Overall Efficiency - 70 - 100% <input type="checkbox"/> 40 - 69% <input type="checkbox"/> 0 - 39% <input checked="" type="checkbox"/>			
5.2 [205]		6 [55]		10 [92]		15 [129]		21 [184]	
mm [in]		Displacement tested at 45°C [113°F] with an oil viscosity of 46cSt [213 SUS]							

020		Pressure - bar [psi]			Max. Cont.		Max. Inter.		
		30 [435]	50 [725]	70 [1015]	100 [1450]	120 [1740]	140 [2030]		
20 cm ³ [1.2 in ³] / rev									
Max. Max. Flow - lpm [gpm]		Torque - Nm [lb-in], Speed rpm						Intermittent Ratings - 10% of Operation	Theoretical rpm
		3 [0.8]	7 [62] 129	12 [106] 123	17 [151] 112	24 [206] 99			
Max. Max. Inter. Cont.		5 [1.3]	8 [71] 226	12 [106] 220	17 [151] 213	25 [221] 199	26 [230] 190		248
		10 [2.6]	7 [62] 477	12 [106] 470	18 [159] 461	25 [221] 450	31 [274] 421	35 [310] 407	497
Max. Max. Inter. Cont.		15 [4.0]	6 [29] 729	11 [97] 722	17 [151] 712	25 [221] 698	30 [266] 680	35 [310] 663	745
		20 [5.3]	5 [43] 975	10 [89] 970	16 [142] 962	24 [212] 952	29 [257] 924	34 [302] 908	994
Max. Max. Inter. Cont.		25 [6.6]		9 [80] 1216	14 [124] 1207	22 [195] 1186	29 [257] 1180	33 [292] 1173	1242
		Rotor Width		Theoretical Torque - Nm [lb-in]		Overall Efficiency - 70 - 100% <input type="checkbox"/> 40 - 69% <input type="checkbox"/> 0 - 39% <input checked="" type="checkbox"/>			
8.0 [316]		10 [85]		16 [142]		22 [199]		32 [284]	
mm [in]		Displacement tested at 45°C [113°F] with an oil viscosity of 46cSt [213 SUS]							

DISPLACEMENT PERFORMANCE

► Performance data is typical. Performance of production units varies slightly from one motor to another. See page 6 for additional information on product testing.

032		Pressure - bar [psi]						Max. Cont.		Max. Inter.		
		30 [435]	50 [725]	70 [1015]	100 [1450]	120 [1740]	140 [2030]					
		32 cm ³ [1.9 in ³] / rev						Intermittent Ratings - 10% of Operation				
		Torque - Nm [lb-in], Speed rpm										
Max. Max. Inter. Cont.	Flow - lpm [gpm]	3 [0.8]	10 [88]								94	Theoretical rpm
		5 [1.3]	10 [88]	18 [157]	27 [239]						157	
		10 [2.6]	11 [97]	19 [168]	27 [239]	40 [354]	47 [413]	55 [487]			314	
		15 [4.0]	10 [88]	19 [168]	26 [230]	39 [345]	47 [413]	55 [487]			472	
		20 [5.3]	9 [80]	17 [159]	26 [230]	38 [336]	47 [413]	54 [477]			629	
		25 [6.6]	6 [53]	15 [128]	23 [203]	36 [318]	44 [385]	51 [451]			786	
		Rotor Width		12.7 [501] mm [in]								
		Theoretical Torque - Nm [lb-in]		15 [134]		25 [224]		35 [314]		51 [448]		
		Displacement tested at 45°C [113°F] with an oil viscosity of 46cSt [213 SUS]										

040		Pressure - bar [psi]						Max. Cont.		Max. Inter.		
		30 [435]	50 [725]	70 [1015]	100 [1450]	130 [1885]	140 [2030]					
		40 cm ³ [2.5 in ³] / rev						Intermittent Ratings - 10% of Operation				
		Torque - Nm [lb-in], Speed rpm										
Max. Max. Inter. Cont.	Flow - lpm [gpm]	3 [0.8]	15 [133]								75	Theoretical rpm
		5 [1.3]	16 [142]	25 [221]	33 [292]						124	
		10 [2.6]	16 [142]	24 [212]	35 [310]	47 [416]	54 [478]	64 [566]			249	
		15 [4.0]	14 [124]	24 [212]	34 [301]	49 [434]	53 [469]	62 [549]			373	
		20 [5.3]	11 [97]	22 [195]	33 [292]	48 [425]	52 [460]	59 [522]			498	
		25 [6.6]	9 [80]	18 [159]	29 [257]	44 [389]	50 [443]	58 [513]			622	
		Rotor Width		16.0 [631] mm [in]								
		Theoretical Torque - Nm [lb-in]		19 [170]		32 [283]		45 [397]		64 [567]		
		Displacement tested at 45°C [113°F] with an oil viscosity of 46cSt [213 SUS]										

050		Pressure - bar [psi]						Max. Cont.		Max. Inter.		
		30 [435]	50 [725]	70 [1015]	100 [1450]	120 [1740]	140 [2030]					
		50 cm ³ [3.1 in ³] / rev						Intermittent Ratings - 10% of Operation				
		Torque - Nm [lb-in], Speed rpm										
Max. Max. Inter. Cont.	Flow - lpm [gpm]	3 [0.8]	17 [150]	29 [150]							60	Theoretical rpm
		5 [1.3]	17 [152]	29 [258]	43 [381]	60 [525]					99	
		10 [2.6]	17 [148]	30 [261]	43 [310]	62 [547]	77 [681]	87 [764]			198	
		15 [4.0]	15 [133]	28 [247]	42 [366]	56 [497]	73 [638]	79 [697]			298	
		20 [5.3]	12 [106]	25 [221]	38 [333]	57 [501]	71 [623]	79 [700]			398	
		25 [6.6]		21 [184]	34 [296]	53 [466]	66 [585]	70 [620]			497	
		Rotor Width		20.0 [787] mm [in]								
		Theoretical Torque - Nm [lb-in]		23 [334]		39 [566]		55 [798]		79 [1146]		
		Displacement tested at 45°C [113°F] with an oil viscosity of 46cSt [213 SUS]										

HOUSINGS

► Dimensions shown are without paint. Paint thickness can be up to 0.13 [.005].

3-HOLE, ROUND MOUNT, ALIGNED SIDE PORTS

JKB G 3/8

JK5 9/16-18 UNF

JLB G 3/8

JL5 9/16-18 UNF

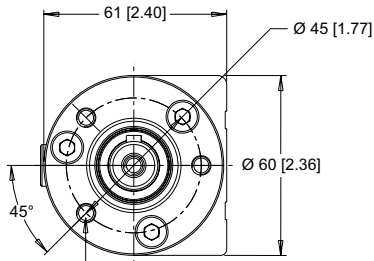

JKB, JK5 - (3) M6 x 1, Min. Depth 10 [.394]
JLB, JL5 - (3) 1/4-28 UNF, Min. Depth 10 [.394]

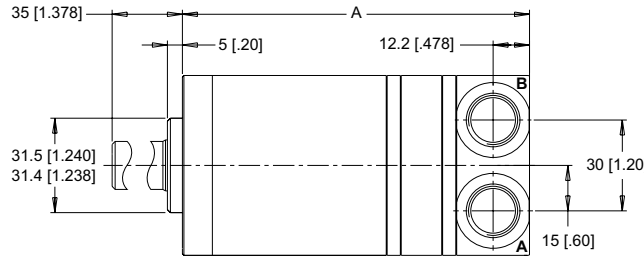

Drain Port: JKB, JLB - G1/8, Min. Depth 8 [.315]
JK5, JL5 - 3/8-24UNF, Min. Depth 10 [.394]

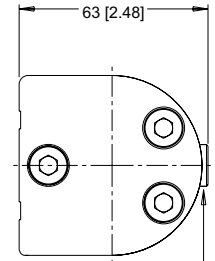

3-HOLE, ROUND MOUNT, ALIGNED END PORTS

JMB G 3/8

JM5 9/16-18 UNF

JNB G 3/8

JN5 9/16-18 UNF

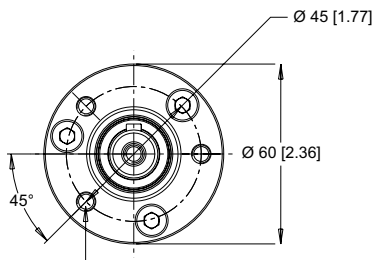

JMB, JM5 - (3) M6 x 1, Min. Depth 10 [.394]
JNB, JN5 - (3) 1/4-28 UNF, Min. Depth 10 [.394]

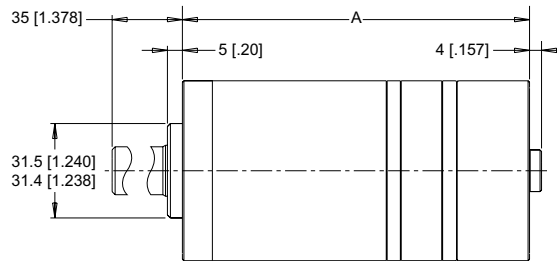

Drain Port: JMB, JNB - G1/8, Min. Depth 8 [.315]
JM5, JN5 - 3/8-24UNF, Min. Depth 10 [.394]

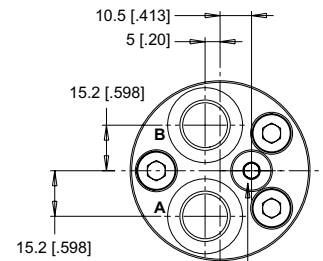

2-HOLE FLANGE MOUNTING KIT (OPTIONAL)

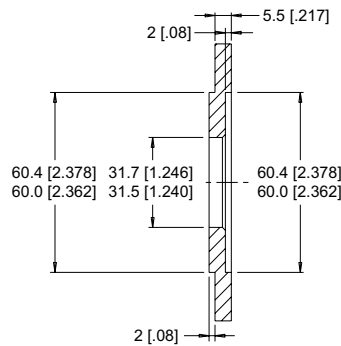
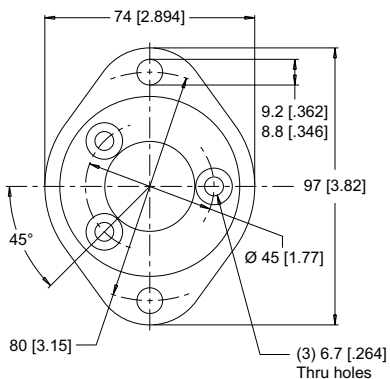

► Reference part number 125017004 when ordering the 2-Hole flange mounting kit. The kit contains three M6 and three 1/4" bolts to accommodate either thread type.

LENGTH & WEIGHT CHART

Dimension A is the overall motor length from the rear of the motor to the mounting flange surface and is referenced on detailed housing drawings above.

A	Length	Weight
#	mm [in]	kg [lb]
008	106 [4.16]	2.2 [4.8]
012	108 [4.23]	2.2 [4.9]
020	110 [4.34]	2.3 [5.0]
032	115 [4.53]	2.3 [5.1]
040	118 [4.66]	2.4 [5.2]

SHAFT & TECHNICAL INFORMATION

C3 5/8" Straight

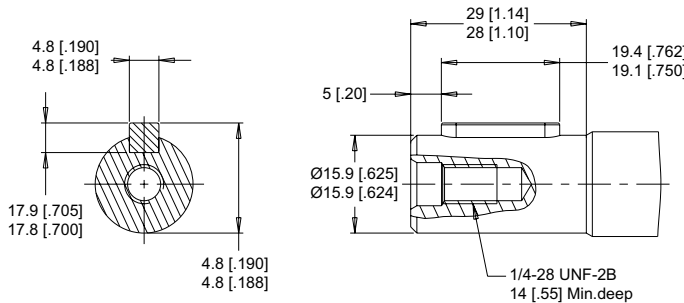

C4 16mm Straight

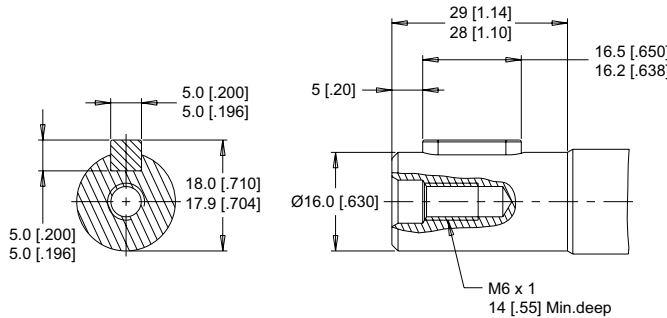

C5 16mm, 9 Tooth Spline

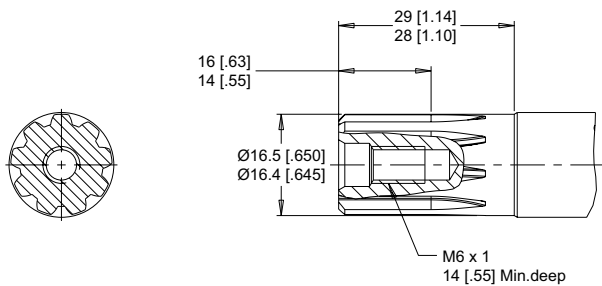

PERMISSIBLE SHAFT SEAL PRESSURE

The curve below represents allowable seal pressure at various speeds. Operation in the gray area results in maintaining the rated life of the shaft seal. Actual shaft seal pressure depends on motor configuration.

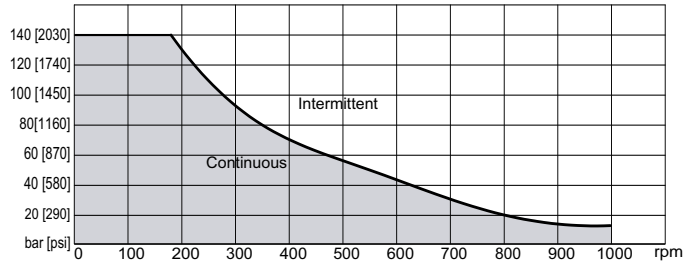

▶ With check valves and drain connection, the shaft seal pressure equals pressure in the drain line. With check valves and no drain connection, shaft seal pressure is identical to output pressure.

PERMISSIBLE SHAFT SIDE LOAD / AXIAL LOAD

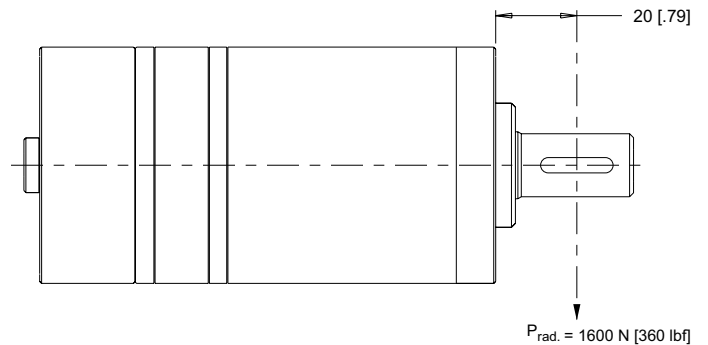

THRUST LOAD

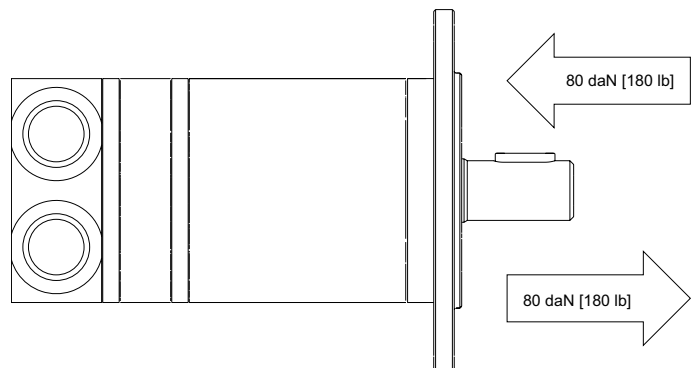

ORDERING INFORMATION

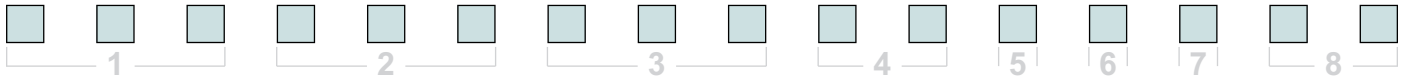

1. CHOOSE SERIES DESIGNATION

- 125** Clockwise Rotation
- 126** Counterclockwise Rotation

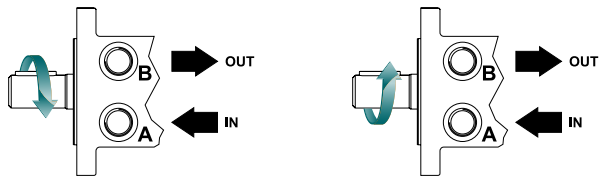

► The 125 & 126 series are bi-directional. Reversing the inlet hose will reverse shaft rotation.

2. SELECT A DISPLACEMENT OPTION

- | | |
|---|---|
| 008 8 cm ³ /rev [0.5 in ³ /rev] | 032 32 cm ³ /rev [1.9 in ³ /rev] |
| 012 13 cm ³ /rev [0.8 in ³ /rev] | 040 40 cm ³ /rev [2.5 in ³ /rev] |
| 020 20 cm ³ /rev [1.2 in ³ /rev] | 050 50 cm ³ /rev [3.1 in ³ /rev] |

3. SELECT A MOUNT & PORT OPTION

- JKB** 3-Hole, M6 Round Mount, Side Ports, G 3/8
- JK5** 3-Hole, M6 Round Mount, Side Ports, 9/16-18 UNF
- JLB** 3-Hole, 1/4" Round Mount, Side Ports, G 3/8
- JL5** 3-Hole, 1/4" Round Mount, Side Ports, 9/16-18 UNF
- JMB** 3-Hole, M6 Round Mount, End Ports, G 3/8
- JM5** 3-Hole, M6 Round Mount, End Ports, 9/16-18 UNF
- JNB** 3-Hole, 1/4" Round Mount, End Ports, G 3/8
- JN5** 3-Hole, 1/4" Round Mount, End Ports, 9/16-18 UNF

► For options not listed in the table above, please contact us with your requirements

4. SELECT A SHAFT OPTION

- C3** 5/8" Straight
- C4** 16mm Straight
- C5** 16mm, 9 Tooth Spline

5. SELECT A PAINT OPTION

- A** Black
- Z** Unpainted

6. SELECT A VALVE CAVITY / CARTRIDGE OPTION

- A** None

7. SELECT AN ADD-ON OPTION

- A** Standard

8. SELECT A MISCELLANEOUS OPTION

- AA** None